

**RUBBER  
EXPANSION  
JOINTS**

**MACOGA**  
ENGINEERED EXPANSION JOINTS



MACOGA  
Rubber Expansion Joints

<b>INTRODUCTION</b>	— 5
<b>FEATURES</b>	— 6
<b>ADVANTAGES</b>	— 7
<b>APPLICATIONS</b>	— 8
<b>CONSTRUCTION DETAILS</b>	— 9
<b>MATERIALS</b>	— 10
<b>ANALYSIS AND DESIGN PRACTICES</b>	— 12
<b>TYPES OF RUBBER EXPANSION JOINTS</b>	— 14
<b>OPTIONAL DEVICES / ACCESSORIES</b>	— 20
<b>DOG-BONE TYPE EXPANSION JOINTS</b>	— 22
<b>ASSEMBLY INSTRUCTIONS</b>	— 24
<b>ON-SITE SERVICE</b>	— 28
<b>CERTIFICATES AND TESTS</b>	— 29



# **MACOGA HAS MORE THAN 40 YEARS OF EXPERIENCE IN EXPANSION JOINTS AND OFFERS THE MOST COMPLETE RANGE EVER CONCERNING SIZES, MATERIAL AND SHAPES TO MEET ALL APPLICATIONS.**

Thermal growth, equipment movement, vibration or pressure pulsation may generate movement in a piping system. When this movement is not absorbed by the piping system itself, an expansion joint is the perfect solution.

A Rubber Expansion Joint is flexible connector fabricated of natural or synthetic elastomers, fluoroplastics and fabrics and, if necessary, metallic reinforcements used to absorb movements in a piping system while containing pressure and a medium running through it.



## FEATURES

### Absorb Axial movements (extension and compression).

Axial movement is the change in dimensional length of the bellows from its free length in a direction parallel to its longitudinal axis.

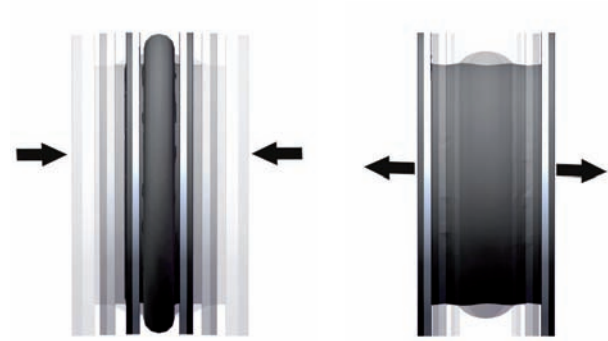

### Absorb Lateral movements.

Lateral movement is the relative displacement of one end of the bellows to the other end in a direction perpendicular to its longitudinal axis.

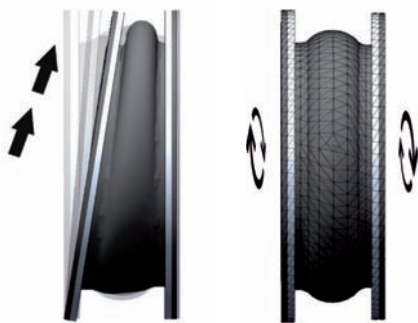

### Absorb Angular and Torsional Movements.

Angular movement is the rotational displacement of the longitudinal axis of the bellows toward a point of rotation. Torsion refers to twisting one end of the bellows with respect to the other end, about the bellows centerline.



### Reduce Vibration.

Rubber expansion joints isolate or reduce vibration caused by equipment. The transmission of vibration is reduced and they protect equipment from these adverse effects.

### Dampen Sound Transmission.

Rubber expansion joints tend to dampen transmission of sound because of the steel-rubber interface of joints and mating flanges.

## ADVANTAGES

### Reduced fatigue factor

Given the inherent characteristics of natural and synthetic elastomers, they are not subject to fatigue breakdown or embrittlement and prevent any electrolytic action because of the steel-rubber interface of joints and mating flanges.

### Extraordinary resistance to abrasion and corrosion

A wide variety of natural, synthetic and special purpose elastomers and fabrics are available to the industry. Materials are treated and combined to meet a wide range of practical pressure/temperature operating conditions, corrosive attack, abrasion and erosion. See table of materials.

### Minimal face-to-face dimensions while absorbing large movements

With a minimal face to face length the Rubber Expansion Joints provide superior movement capability in axial compression, axial extension, and lateral deflection, as well as in the angular and torsional direction.

### Low Spring Rates due to inherent flexibility of rubber

The inherent flexibility of rubber expansion joints permits almost unlimited flexing to recover from imposed movements, requiring relatively less force to move, thus preventing damage to motive equipment.

### No gaskets required for installation

Elastomeric expansion joints are supplied with flanges of vulcanized rubber and fabric integrated with the tube, making the use of gaskets unnecessary in most of the applications. Check assembly instructions before installation.

### Lightweight

Rubber Expansion joints are relatively light in weight, contributing to lower installation labour costs.

### Reduced Heat Loss

Rubber expansion joints reduce heat loss, giving long maintenance-free service



# APPLICATIONS

- Power generating stations
- Oil & gas
- Desalination
- Cooling systems
- Pumps
- Chemical plants
- Heating, ventilating and air conditioning
- Shipbuilding
- Off-shore applications
- Water treatment plants
- Sewage
- Sanitary piping systems
- Pulp and paper plants
- Piping systems for chilled or hot water
- Cooling systems power generation
- Phosphate plants
- Potable water
- Food process





## CONSTRUCTION DETAILS

MACOGA rubber expansion joints are designed following the guidelines of the **FSA (Fluid Sealing Association) Non-Metallic Expansion Joints Technical Handbook, ASTM F1123 - 87 Standard Specification for Non-Metallic Expansion Joints** and always complying with the **European Pressure Equipment Directive 2014/68/UE** for the specified operating conditions.

MACOGA Rubber Expansion Joints are manufactured considering:

- Chemical resistance of internal layers.
- Temperature resistance.
- Movement absorption capabilities.
- Pressure resistance.
- Weather, ozone and UV-resistance of external layers

Rubber Expansion joints are fabricated with an elastomeric tube reinforced with multiple plies of fabrics covered with synthetic rubber. The inner tube is made of natural rubber, synthetic rubber or blend of synthetic rubber. The fabrics are Nylon®, Polyester, Aramid or Kevlar®. An additional reinforcement to the fabric may be provided in the body of the expansion joint and may be solid metal rings or wire embedded in the rubber.

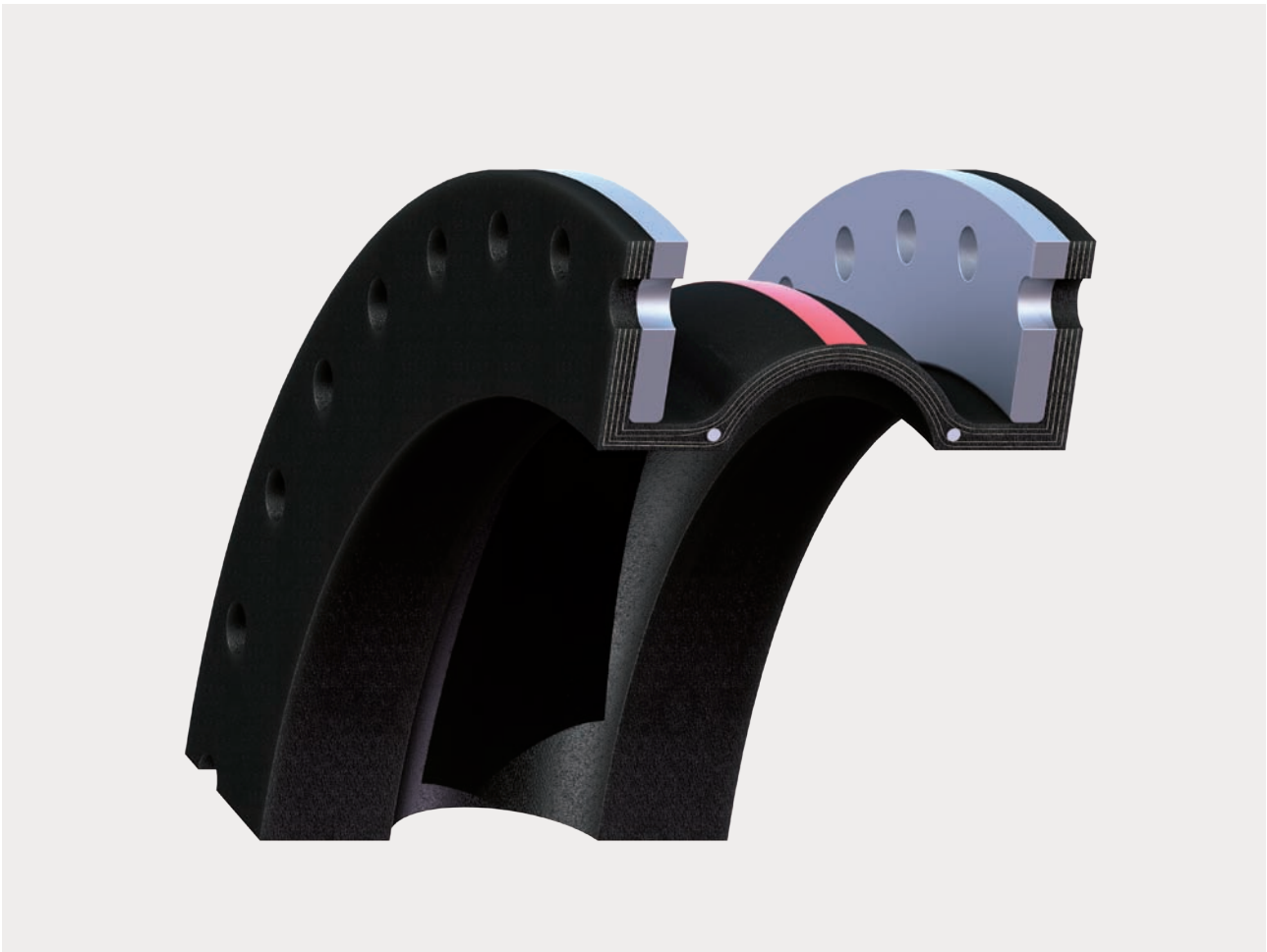

## MATERIALS

### Rubber bellows

A rubber bellow is manufactured from independent rubber layers and reinforcements that are vulcanized together after being molded or formed.

With over 35 rubber elastomers available and the ability to further modify properties by compounding it can be challenging for non-specialists to select the most appropriate rubber polymer for their requirements. Our experts may assist our customers with material selection for a proper performance and to reduce the risk of failure.

### Fabric reinforcements

Standard constructions normally utilize high quality synthetic fabric like Nylon®, Polyester,

Aramid or Kevlar®. Fabric plies are impregnated with rubber or synthetic compounds to permit flexibility between the fabric plies.

### Metal reinforcements

Wire or solid steel strings are imbedded in the carcass and are used as strengthening members of the joint.

### Flanges

Carbon steel as standard. Also available in zinc plated or hot dip galvanized carbon steel, stainless steel, duplex, etc. Flanges drilled to EN, ANSI, JIS, AWWA standards or any specific dimension.



	Abbreviation	Name	Temp. Range °C	Properties	Application
RED	EPDM	Ethylene Propylene Diene Monomer	-35 to +100	Weather-resistant, good gas tightness, resistant to attack by oxygen, U.V., ozone and extreme weather environments.	Hot water, cooling water with salt solutions, chlorine solutions, ester, ketones, compressed air (oil free) and chemicals except for hydrocarbons.
DOUBLE RED	EPDM HT	Ethylene Propylene Diene Monomer HT	-35 to +140	Special EPDM rubber compound suitable for high temperature up to 140 °C applications without hardening. Weather-resistant, good gas tightness, resistant to attack by oxygen, U.V., ozone and extreme weather environments.	High temperature applications up to 140 °C. Hot water, cooling water with salt solutions, chlorine solutions, ester, ketones, compressed air (oil free) and chemicals except for hydrocarbons.
RED+WHITE	EPDM DW	Ethylene Propylene Diene Monomer DW	-35 to +90	FDA Approved.	Drinking water.
YELLOW	NBR Nitrile	Nitrile Butadiene Rubber	-40 to +90	Good general resistance to oils and hydrocarbons. Good mechanical properties especially tensile strength, flexibility, compression set and impermeability to gases. Moderate ageing properties. Good abrasion resistance.	Oil and fuel, also suitable for gases, solvents and fats. Mineral oils, vegetal and animal oils, oils aerosols, butane or propane gas. Not suitable for steam and hot water.
DOUBLE YELLOW	NBR HT	Nitrile Butadiene Rubber HP	-40 to +140	Good general resistance to oils and hydrocarbons. Good mechanical properties especially tensile strength, flexibility, compression set and impermeability to gases. Moderate ageing properties. Good abrasion resistance.	High temperature applications up to 140 °C. Oil and fuel, also suitable for gases, solvents and fats. Mineral oils, vegetal and animal oils, oils aerosols, butane or propane gas. Not suitable for steam and hot water.
WHITE	NBR-W	White Nitrile Butadiene Rubber	-20 to +90	FDA approved material and has good resistance to oils and greases.	Foodstuff, good for pulps, flours, juices and wines. Food and beverages, including fats and oils.
GREEN	CSM HYPALON	Chloro- sulfonated polyethylene synthetic rubber	-25 to +90	Excellent resistance to oxidation. Outstanding resistance to atmospheric conditions and in particular strong sunlight and ozone. CSM compounds resist fire and are self-extinguishing.	Strong and/or concentrated acids and bases, freons, hydroxides, ozone, compressed air that bears oil aerosols, etc.
BLUE	SBR	Styrene-butadiene rubber	-25 to +85	Good resistance to abrasion. Excellent mechanical properties. Only moderate resistance to tearing, ozone and general weathering.	Wearing material such as sludge suspended stones, calcium, etc.
BLACK	CR NEOPRENE	Polychloroprene	-25 to +90	The best multi-function rubber. Good resistance to temperature changes, ozone action and adverse weather conditions. Good mechanical and abrasion properties. Resistance to chemicals; resistant to inorganic chemical products except oxidizing acids and halogens. Moderate resistance to aliphatic hydrocarbons.	Water, warm water, seawater, air and weak acids. Suitable for some small groups of acids as well as compressed air and lightly oil-related media.
RED+BLUE	IIR BUTYL	Isobutylene isoprene rubber	-30 to +120	Low gas permeability. Good ozone and weather resistance. Resistant to oxidizing agents, vegetable and animal fats and polar solvents. Poor wear resistance. Not resistant to hydrocarbon solvent and oil.	Animal and veg. oils, fats, greases, air, gas, water, many oxidizing chemicals and ozone.
BROWN	NRL NATURAL RUBBER	Natural rubber	-25 to +80	Excellent mechanical properties. It has excellent tensile, elongation, tear resistance and resilience. Excellent abrasion resistance and excellent low temperature flexibility. Poor resistance to ozone, oxygen, sunlight and heat. It has poor resistance to solvents and petroleum products.	Seawater, sewage, resist weak acids and alkalis. Up to 65 °C it has a good resistance against: hydrochloric acid in any concentration, sulfuric acid up to 50% concentration, sodium hydroxide, diluted and concentrated potassium hydroxide.
GREY	BR POLYBUTADIENE	Polybutadiene	-40 to +80	Excellent mechanical properties. Excellent abrasion resistance and excellent low temperature flexibility. Poor resistance to attack by petroleum oils, poor ozone, UV resistance.	Up to 65 °C it has a good resistance against: hydrochloric acid in any concentration, sulfuric acid up to 50% concentration, sodium hydroxide, diluted and concentrated potassium hydroxide.
PURPLE	VITON FKM (ASTM) FPM (DIN/ISO)	Fluorine-polymer	-20 to +150	Good flame resistance, resistance to oxygen, ozone and natural weathering. Poor performance against ethers, ketones, and bases.	High concentrated chemicals up to 150 °C. Hydrocarbons, aliphatic, aromatic and chlorinated chemicals. Good resistance to acids and alkali's including oxidants. Good resistance to chemicals, oils, combustibles and solvents.

Note: Temperatures listed above are the typical maximum degree ratings for continuous use.

## ANALYSIS AND DESIGN PRACTICES

Our analysis and design practices include:

- Finite Element Analysis (FEA)
- Pipe Stress Analysis
- CAD
- 3D Modelling

We use the most sophisticated analysis and calculation software to design pipe systems and select the most appropriate Expansion Joints providing a complete pipe stress analysis when required.

With our 3D mechanical CAD software our engineers design Expansion Joints to the same conditions that they'll experience in the real world before they have been built. This is a design validation tool that helps our engineers to test the designs earlier in the design cycle and against real-world conditions. This lead us to improved design quality and manufacturing efficiency, while reducing time to market, costs and materials waste.

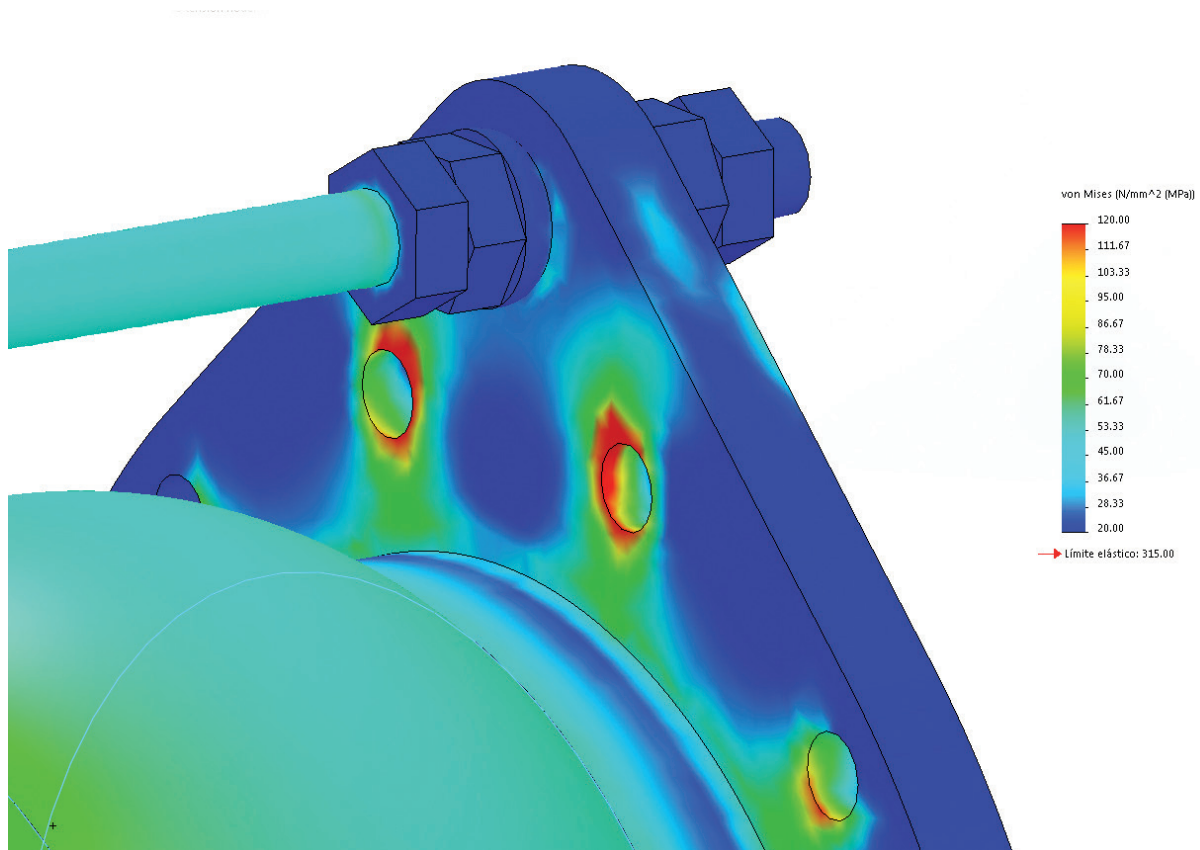





MAC JOINTS MAC-F SERIES

CE 0056  
Mod. H

MADE IN ITALY EXPANSION JOINTS - WWW.MACFJ.COM

# TYPES OF RUBBER EXPANSION JOINTS

## MOULDED OR CUSTOM MADE EXPANSION JOINTS WITH FLOATING FLANGES

### MAC-W AND MAC-WT SERIES

These are the standard moulded or custom made Expansion Joints consisting of high quality rubber body incorporating floating flanges.

Rubber bellows: Reinforced EPDM, EPDM HT, Nitrile, Spec. Nitrile, Nitrile white, Hypalon, SBR, Viton®, Chloroprene, etc.

Flanges: Zinc plated carbon steel as standard. Also, available in hot dip galvanized carbon steel, stainless steel, etc. drilled to EN and ANSI standards. On request, flanges are also available drilled to JIS and AWWA standards.

For vacuum applications, an internal stainless steel vacuum ring is incorporated.

Standard moulded construction from DN 32 to DN 1000 (see table for standard dimensions). Larger sizes can be supplied custom made up to DN 6000.

### MAC-W / Unrestrained

A high quality moulded or custom made single arch unrestrained expansion joint consisting of a rubber bellow incorporating floating flanges.

This model absorbs all the movements in any one length of piping.

Unrestrained expansion joints under pressure will exert a considerable axial force on the pipeline, i.e. anchors. It is essential that checks are carried out when the expansion joint is first pressurized to ensure that there is no unforeseen stretching of the bellows. If unforeseen movement is apparent, then



MAC-W Series

the pipe guides or anchors shall be examined to ensure that they have been installed correctly and sufficiently designed for the duty.

MAC-W & MAC-WT standard dimensions  
Specific dimensions can be provided custom made.

DN	Lenght mm	Compression mm	Extension mm	Lateral mm	Angular deg	Working pressure
32	130&150	30	20	20	30	16
40	130&150	30	20	20	30	16
50	130&150	30	20	20	30	16
65	130&150	30	20	20	30	16
80	130&150	30	20	20	30	16
100	130&150	30	20	20	25	16
125	130&150	30	20	20	25	16
150	130&150	30	20	20	15	16
200	130&200	30	20	20	15	16
250	130&200	30	20	20	10	16
300	130&200	30	20	20	10	16
350	200	30	20	20	10	10
400	200	30	20	20	10	10
450	200	30	20	20	10	10
500	200	30	20	20	10	10
600	200	30	20	20	6	10
700	275	40	25	30	5	10
200	275	40	25	30	4	10
900	300	40	25	30	3	10
1000	300	40	25	30	3	10





MAC-WT Series

**MAC-WT / Restrained**

As MAC-W but incorporating control units/tie rod system. A control unit assembly is a system of 2 or more control rods placed across the expansion joint from flange to flange to set the maximum allowable expansion/contraction of the expansion joint and that will contain the pressure thrust. Recommended on most applications to prevent damage due to excessive pipe movements, each rod incorporates double nuts on each end to keep the expansion joint from over- elongating and spherical washers to allow Lateral, Angular and some Torsional movements as well as to accommodate moderate piping misalignments.

**EXPANSION JOINTS WITH FULL FACE RUBBER FLANGE**

**MAC-F & MAC-FT SERIES**

High quality custom-made expansion joints supplied with split or fixed steel backing flanges. The full face flanges are integral with the body of the joint and drilled to conform the bolt pattern of the companion flanges of the pipe line.

Rubber bellows: Reinforced EPDM, EPDM HT, Nitrile, Spec. Nitrile, Nitrile white, Hypalon, SBR, Viton®, Chloroprene, etc.

Flanges: shot-blasted and painted carbon steel as standard. Also available in hot dip galvanized carbon steel, stainless steel, etc. Drilled to EN, ANSI, AWWA, JIS standards or any specific dimension.

For vacuum applications, an internal vacuum ring is incorporated.

MAC-F and MAC-FT can be supplied with one or more arches.

Dimensions from DN 15 to DN 6000.



MAC-F Series

**MAC-F Series / Unrestrained**

A high-quality custom made single arch unrestrained expansion joint consisting of a rubber bellows incorporating full face rubber flanges and metal backing flanges.

This model absorbs all the movements in any one length of piping.

Unrestrained expansion joints under pressure will exert a considerable axial force on the pipeline, i.e. anchors. It is essential that checks are carried out when the expansion joint is first pressurized to ensure that there is no unforeseen stretching of the bellows. If unforeseen movement is apparent, then the pipe guides or anchors shall be examined to ensure that they have been installed correctly and sufficiently designed for the duty.



#### MAC-FT Series

##### MAC-FT Series / Restrained

Like MAC-F but incorporating control units or tie rod system.

Expansion joints expand in length when under pressure. The force created by this pressure is designated as Pressure thrust. Where the pipe supports and anchors are not designed to absorb this force, tie rods across the joint must be incorporated. Tie rods are designed to take the full pressure thrust and tie rods supports are integrated in the flanges (retaining rings) so there is no thrust on counter flanges.

A control unit assembly is a system of 2 or more control rods placed across the expansion joint from flange to flange to set the maximum allowable expansion/ contraction of the expansion joint and will absorb the pressure thrust.

Recommended on most applications to prevent damage due to excessive pipe movements, each rod incorporates double nuts on each end to keep the expansion joint from over elongating and spherical washers to allow lateral and some angular movements (2 tie rods only).

#### VARIATIONS

##### Multiple arch type

Expansion joints with two or more arches (convolutions) may be manufactured to accommodate movements greater than those of which a single arch type joint is capable of. Length of the joint is dependent on the number of arches.



#### Multiple arch type

##### Filled Arch Type

Filled arch-type expansion joints may be supplied with a bonded-in-place soft rubber filler to provide a smooth interior bore. Filled arch design reduces possible turbulence and prevents the collection of solid materials that may settle from the solution handled and remain in the archway. Filled arch joints also have a seamless tube so the arch filler cannot be dislodged during service.

##### Advantages

- Reduces flow turbulences
- Avoids solid deposits in the corrugations.
- Disadvantages
- Decrease the flexibility. Movements of expansion joints with filled arches are limited to 50% of the normal movements of comparable size expansion joints with unfilled (open) arches.



Filled Arch Type



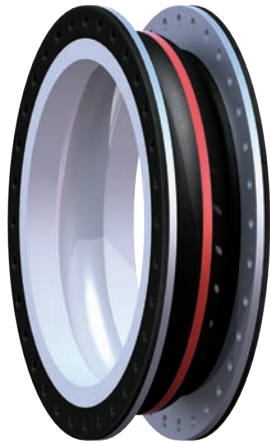

PTFE lining

**PTFE lining**

MAC-F or MAC-FT spool arch type joints are available in many standard pipe sizes with fluoroplastic lining of PTFE and/or FEP. These lining is fabricated as an integral part of the expansion joint during manufacture and cover all wetted surfaces in the tube and flange areas. Fluoroplastic provides exceptional resistance to almost all chemicals within the temperature range of the expansion joint body construction.



Rectangular

**RECTANGULAR**

MACOGA Rubber expansion joints can be manufactured in square or rectangular shape and in any dimension. They can be also produced with or without arch and with multiple arch design for absorbing greater movements.



Reduced type

**Reduced type**

Reducing expansion joints are designed and manufactured to allow the connection of different diameter pipes. There are two main types of reducer: concentric and eccentric reducers. Reducers are usually concentric but eccentric reducers are used when required to maintain the same top-or bottom-of-pipe level.





## OTHER STYLES

Universal tied, hinge, gimbal, in-line pressure-balanced and elbow pressure-balanced are also possible. They all incorporate a restrained design, which manages pressure thrust forces in the piping system. The selection and application of these Rubber Expansion Joints categories are particularly useful in systems that have support structures or adjacent equipment with load limitations. All these styles can absorb set movements, reduce noise and vibration, have a long cycle life, compensate for planned misalignments and relieve pipe and anchor stresses.

**Universal tied rubber expansion joints** feature two resilient arch sections separated by a straight section to facilitate greater lateral-movement capability and a set of control or tie rods system. Control units are used as limit rods for secondary restraint in a properly anchored piping system, or as tie rods when the support structure or adjacent equipment have load limitations.

**Hinge rubber expansion joints** are designed to absorb angular movement in one plane only. The arrangement consists of a pair of hinge plates connected with pins and attached to the expansion joint's hardware. The hinge assembly must be designed for the internal pressure thrust forces of the system. These Expansion Joints can be used in sets of two or three to absorb large lateral movements in a single plane.

**Gimbal rubber expansion joints** are designed to facilitate and isolate angular movement in all planes. The arrangement consists of two pairs of hinge plates connected with pins to a common gimbal ring and attached to the expansion joint's hardware. The gimbal assembly must be designed for the internal pressure thrust forces of the system. They can be used in sets of two or sets of two with a single-hinge design to absorb large lateral movements in multiple planes.

**In-line pressure-balanced rubber expansion joints** provide the only effective solution for directly absorbing large axial thermal movements (a specific design can also be provided to absorb some lateral movements) while continuously self-restraining the pressure thrust forces. This arrangement consists of tie devices interconnecting the main joint sections to the opposing balancing joint section and is commonly used when the support structure or adjacent equipment have load limitations.

**Elbow pressure-balanced rubber expansion joints** are designed to absorb all directional movement while continuously self-restraining the pressure thrust forces. This consists of tie devices interconnecting its main joint section to its opposing balancing joint section and is often used when the support structure or adjacent equipment have load limitations.



## OPTIONAL DEVICES / ACCESSORIES

### External protective shields, covers and flame guards

Unusual applications of rubber expansion joints may require the specification of: protective shields, protective cover or fire cover. These three types of covers, when manufactured of metal, have one end which is bolted to or clamped to the mating pipe flange. The other end is free, designed to handle the movements of the expansion joint.

**Protective shields** should be used on expansion joints in lines that carry high temperature or corrosive media. This shield will protect personnel or adjacent equipment in the event of leakage or splash. Wrap around protective shields of fluoroplastic impregnated fiberglass are the most common.

**Protective covers** of expanded metal are used to prevent exterior damage to the expansion joint. Fire covers, designed oversize, are insulated on the I.D. to protect the expansion joint from rupture during a flash fire. They are normally installed on fire water lines.

Sun covers protect the elastomer against UV radiation. When possible, it is not recommended to insulate over elastomeric expansion joints.

#### CAUTION:

Protection / Spray shield have some insulating properties. The containment of system temperatures can accelerate the aging of the product and makes required external inspections difficult.

### Internal liner

Consists of a sleeve extending through the bore of the expansion joint with a full-face flange on one end. Constructed of hard rubber, metal or fluoroplastic it reduces frictional wear of the expansion joint and provides smooth flow, reducing turbulence. This type sleeve should not be used where high viscosity fluids, such as tars, are being transmitted. These fluids may cause packing-up or caking of the arch area, which reduces movements and in turn may cause premature expansion joint failure.

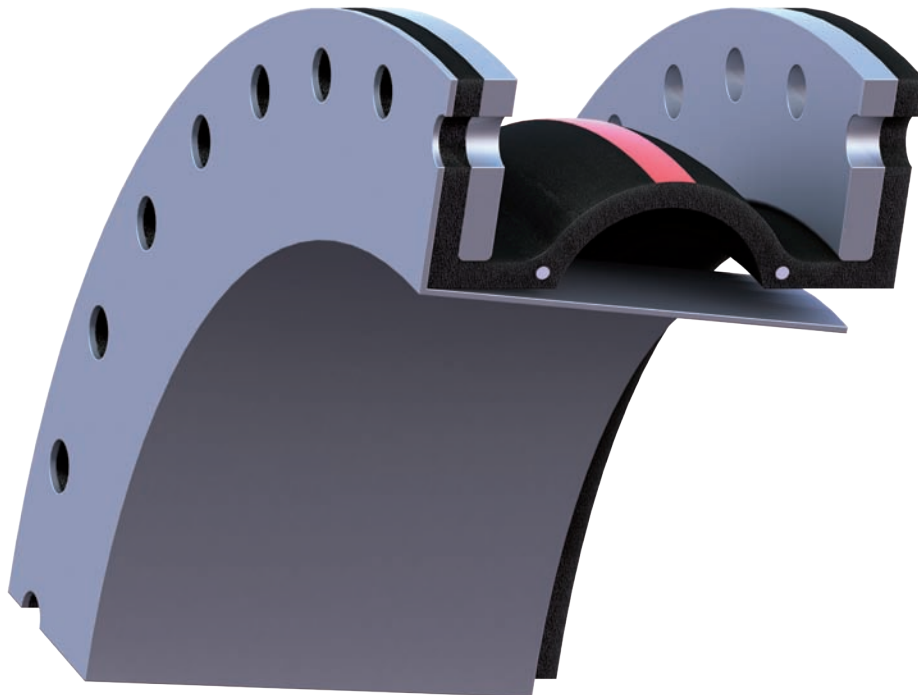



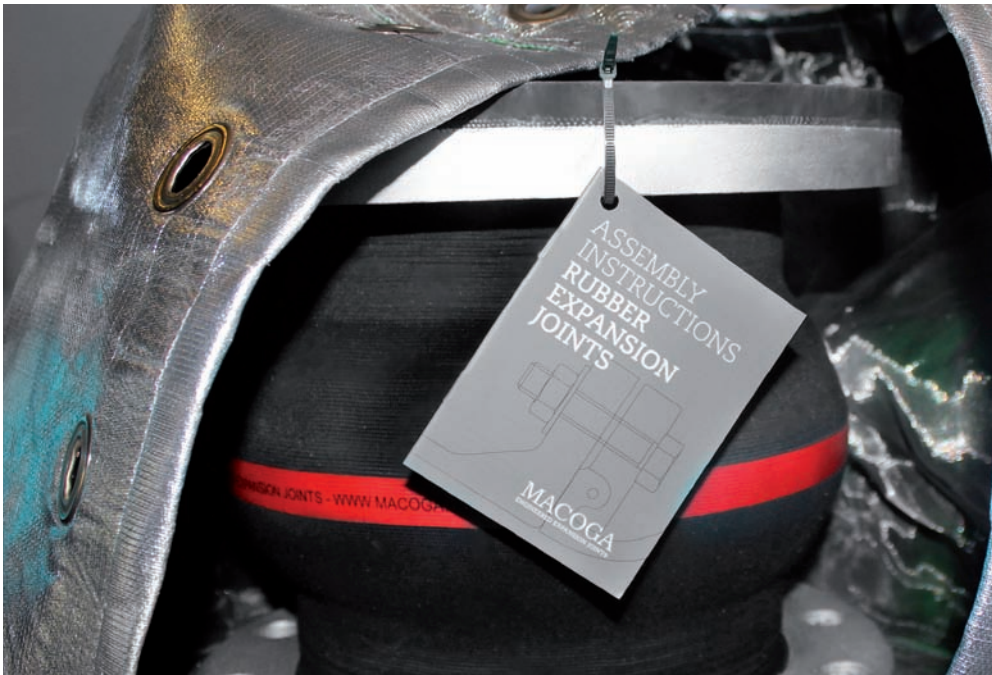
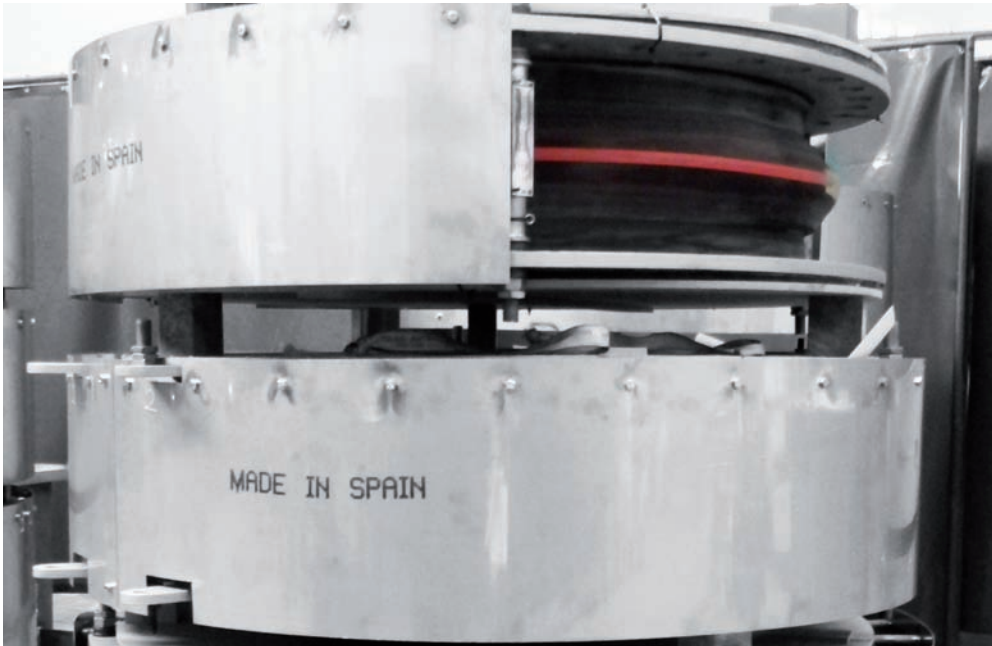

## DOG-BONE TYPE EXPANSION JOINTS

The Dog Bone Type Expansion Joint is used as flexible connection between Turbines and Condensers. Used as a flexible connection in power plants it is the most widely used turbine to condenser expansion joint in use. One of the main functions of the Dog Bone Expansion Joint is to absorb the differential thermal expansion between the steam turbine and the condenser while imparting minimal forces and moments on the turbine exhaust flange. Steam turbines come in a variety of exhaust configurations such as down exhaust, axial exhaust and top exhaust. Each configuration has unique design and performance requirements for the expansion joint. The expansion joint must perform satisfactory under a wide range of operating conditions to ensure reliable operation of the turbine condenser system. MACOGA provides the highest Quality Dog-Bone Type Expansion Joints.

### MULTIPLY MOULDED BELT

A moulded construction of plies of rubber impregnated fabric, rubber covered and spliced endless to a specific peripheral dimension.

Dog Bone Expansion Joints can be made of Neoprene (Poly-Chloroprene) or EPDM (Ethylene Propylene Polymer).

- **Standard overall width :** 240 mm (9-3/8")
- **Rubber Material :** EPDM or Neoprene
- **Reinforcements :** 6 (standard) or 8 ply polyester 500 warp x 500 fill tensile strength
- **Knobs :** 32 mm (1-1/4") diameter
- **Core :** 16 mm (5/8") Polypropylene cord

### Maximum temperature rating

- **EPDM**
  - Continuous : 121 °C (250 °F)
  - Intermittent: 194 °C (350 °F) max. 36 hours whole life
- **Neoprene**
  - Continuous :** 107 °C (225 °F)
  - Intermittent:** 152 °C (275 °F) max. 36 hours whole life

### Pressure rating

- 1 bar (15 psig) / Full Vacuum

### Rate movements (for a standard 240 mm width)

- **Axial Compression :** 25 mm (1")
- **Axial Extension :** 3 mm (1/8")
- **Lateral Movement :** 12 mm (1/2")

### CLAMPS

The rubber belt expansion joint equipped on both sides with self-sealing rubber knobs, affixed to the connecting metal parts using specially designed machined clamps that ensure tightness. The machined clamps and the bolting ensure leak tightness during operation. The clamps on either end are welded to a flange if the expansion joint is to be bolted to the condenser and the turbine. The clamps are welded to filler piece of a weld end if the expansion joint is to be welded to the turbine or the condenser.

### INNER LINER

The internal liner secures a smooth flow, protects bellows from flow induced vibrations, hold friction to a minimum and protect bellows from erosion.

### CONNECTING ENDS

In carbon steel material as standard, they can be supplied with landing bars or weld ends for welding to customer's ducting or with flanges drilled to match customer's equipment.

### ON SITE SERVICE

MACOGA Site Staff of expert technicians is available on and as-needed basis. Our service group consists of highly-qualified technicians and engineers specialized in expansion joints. Our staff is well trained with regard to health and safety issues. Compliance with international, local, customer and company regulations is mandatory, and is assessed on a regular basis.

We offer our customer custom made and professional solutions to solve their site needs as follows: Installation Package, Supervising Package and Assembly Package.

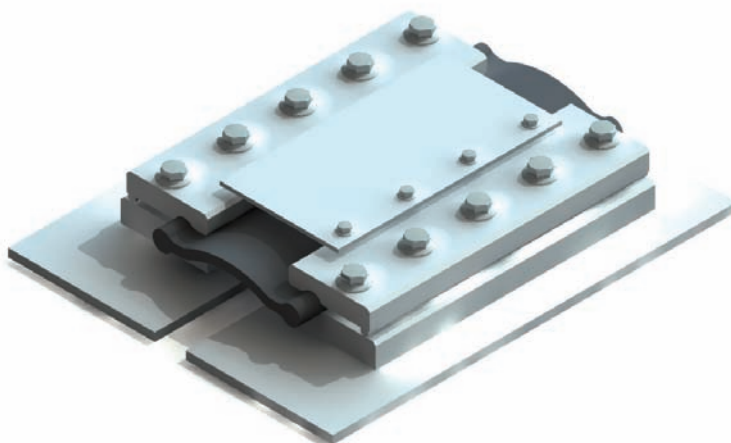

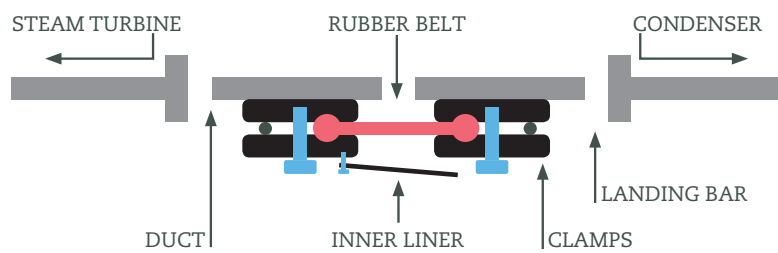
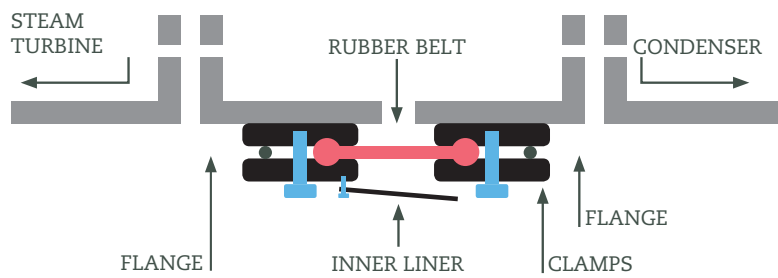
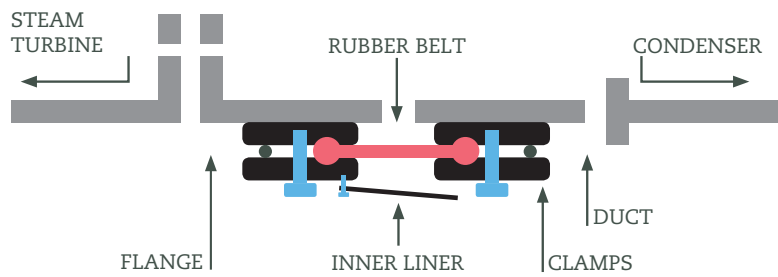
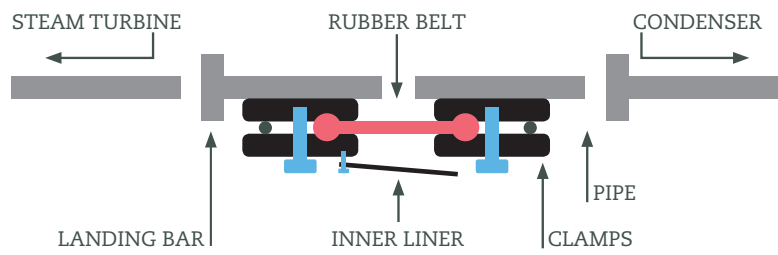
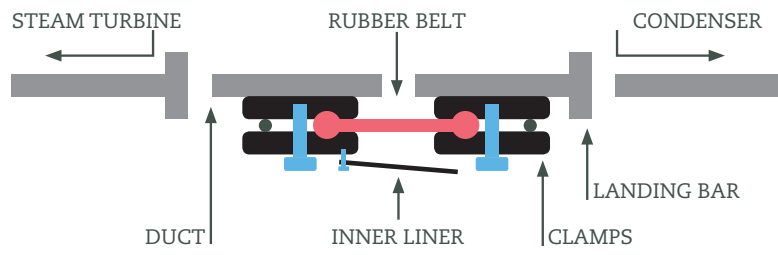



## ASSEMBLY INSTRUCTIONS

When in doubt about an installation procedure please contact macoga technical department before attempting to install the expansion joint. Macoga's warranty may be void if improper installation procedures have been used.

### ASSEMBLY INSTRUCTIONS FOR RUBBER EXPANSION JOINTS

This document gives general guidance for proper storage, unpacking, handling and assembly of MACOGA Rubber Expansion Joints. In case of doubt we recommend that you contact MACOGA directly and inquire about your specific question. In order to ensure that the Expansion Joint work properly and in order to prolong its working life, it is necessary to respect a series of precautions that make the Expansion Joints almost maintenance free elements. The most important precautions that must be observed are as follows:

#### Unpacking & Handling

- Unpack the Expansion Joints carefully.
- Only use rounded objects to unpack the expansion joints.
- Use only designated lifting lugs to lift the Expansion Joints.
- Do not lift the expansion joint by the shipping bars.
- Do not lift the expansion joint by the hinges, gimbals, tie rods or any other operative device.
- Do not fix any chains or ropes to the bellows section. The bellows portion of the expansion joint may be easily damaged and cannot usually be repaired.
- Inspect the units directly after unpacking has been completed. Report any damage immediately to your Engineering/Inspection Department for correct disposition.
- Do not remove any blocking/transport device (yellow marked and clearly identified) if available until the Expansion Joint has been installed.

Clamping torque in Nm for MAC-W Series

DN	Lenght mm	WP bar	Torque Nm
32	130&150	16	60
40	130&50	16	60
50	130&150	16	60
65	130&150	16	60
80	130&150	16	60
100	130&150	16	80
125	130&150	16	80
150	130&150	16	80
200	200&130	16	80
250	200&130	16	80
300	200&130	16	80
350	200	10	130
400	200	10	130
450	200	10	130
500	200	10	130
600	200	10	210
700	275	10	250
800	275	10	300
900	300	10	310
1000	300	10	340

Clamping torque in Nm for MAC-F Series

DN	Torque Nm		
	DIN PN6	DINPN10	AWWA/ANSI
400	150	200	300
450	150	200	300
500	150	200	300
600	200	300	400
700	250	300	400
800	300	450	600
900	350	450	650
1000	350	600	700
1100	450	600	700
1200	500	750	700
1300	600	900	950
1400	600	900	1000
1500	650	1200	1000
1600	650	1200	1200
1800	750	1200	1200
1900	900	1200	1500
2000	900	1350	1600
2200	1000	1700	1700
2400	1000	1800	2200
2500	1200	1800	2200
2600	1300	1800	2200
2800	1350	1900	2200

## Installation

- Special care should be taken to avoid any damage to the bellows.
- Any field pre-positioning or pre-setting carried out when installing the Expansion Joints must be performed in accordance with the specific instructions supplied by MACOGA, including both the direction and magnitude of the movement.
- Expansion Joints must be fitted in the appropriate longitude as laid out in the instructions supplied by MACOGA. The Expansion Joints should not be stretched or compressed in order to absorb any defects along the length of the pipe or to rectify any misalignments unless this was taken into account during the initial design and the manufacturing process.
- Once the Expansion Joint has finally been installed and secured, all of the shipping devices, if any, must then be removed and not before.
- For Expansion Joints with internal sleeve, the Expansion Joint must be fitted according to the direction of flow in relation to the internal sleeve.
- Check the dimensions of the installation gaps. Do not allow the total of the assembly tolerances and the movements to be accommodated to exceed the maximum allowable movement.
- The pipe flanges must be smooth, flat and free of burrs.
- Clean the pipe flanges and remove anticorrosion protective coatings from the surfaces.
- The screw holes of the pipe flanges must be aligned. The expansion joint must not be subject to torsion.
- Tools required: torque wrench, rubber mallet, centering pins. Do not use any tools with sharp edges.
- Carefully push the expansion joint into the installation gap. It is important to avoid damaging the sealing surfaces.
- Do not install any additional seals between the expansion joint sealing surfaces and the pipe flange. The rubber flange or sealing bulge of the expansion joint forms a direct seal against the pipe flange.
- Insert the fixing screws and tighten by hand.
- For clearance holes, insert screws with the head toward the expansion joint bellows.
- Otherwise, select a screw excess length short enough that the screw bolt will not damage the expansion joint bellows, even under pressure and in the event of movements.
- The sealing surface of the expansion joint should be strained together evenly all around.
- The required clamping torque for the flange screwing should be applied crosswise with a torque wrench in three (3) steps.

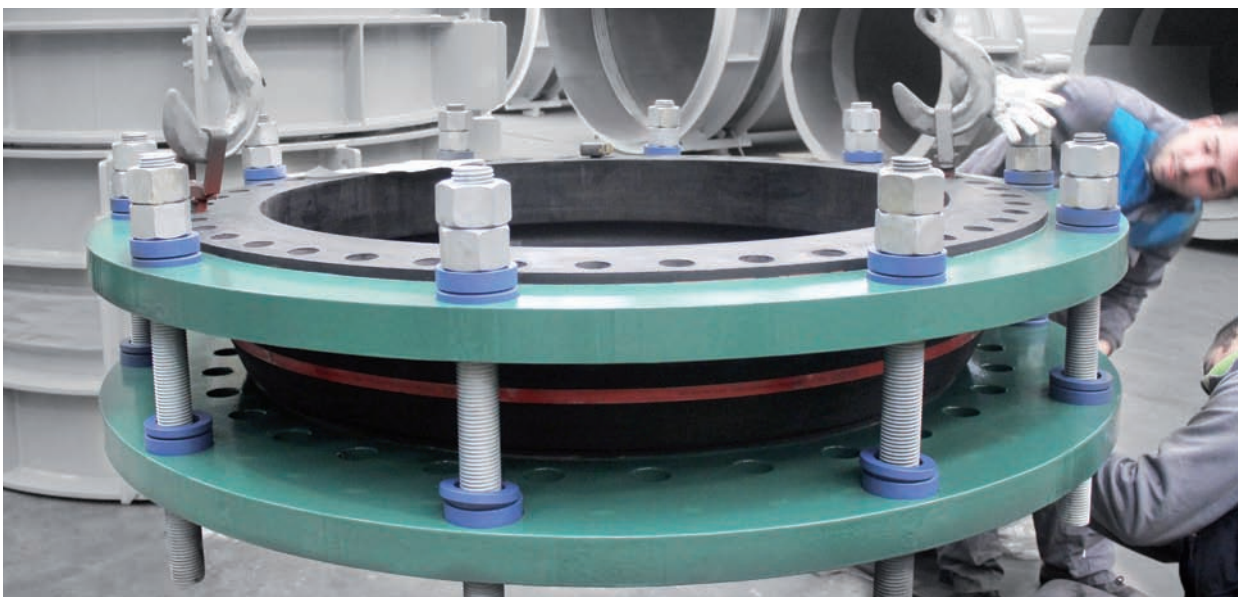

**Step 1.** Apply 1/3 of the final clamping torque crosswise and evenly in approximately three passes. Check the gap width at the outer edge of the flange. Settling time > 30 minutes.

**Step 2.** Re-tighten all screws crosswise in 3 passes using 2/3 of the final clamping torque. Check the gap width at the outer edge of the flange. Settling time > 60 minutes.

**Step 3.** Apply the final clamping pressure in 2 passes, cross-wise.

- No further retightening needed.
- Do not significantly exceed the indicated maximum clamping torque.
- Protect the expansion joint against damage until commissioning using a suitable covering.

#### **Prior to starting up**

- Remove any dust or foreign materials which may have found their way inside the expansion joint.
- Check if the expansion joint is designed for the pressure, temperature and medium specified.
- Check for any possible damage during handling or installation. Check the outer surface of the expansion joint for signs of deterioration such as discoloration, cracked or grainy surface, or a visible reinforcement layer.
- Ensure that the Expansion Joint fit in the correct place.
- If inner liners are available, make sure that the Expansion Joint is properly installed with regards to the direction of flow. Please check the flow direction arrow if any.
- Verify that the Expansion Joint will not be exposed to any contaminants (oil or grease, fuels, acids, or chemicals) for which it is not designed.
- Confirm that all of the supporting structures and anchorage been correctly installed as planned.
- Make sure that the Expansion Joint is not misaligned.

#### **When starting up**

- Check for leakage.
- If necessary, check efficiency of tie rods.

#### **When running**

- The expansion joint must be never covered with insulating material or paint.
- Check, that the expansion joint is protected against direct and indirect sunlight, ozone from electrical equipment, oil and gasoline fumes, rodents, etc.
- Make sure the expansion joints are not subject to movements beyond their allowable limits.

#### **Expansion joint maintenance**

It is recommended to perform inspections one week after operational start and then every 12 months.

Check for:

- External damages to the bellows, flanges or tie rods.
- Any changes in the outer cover may be indicative of serious deterioration. Changes to the bellows such as blisters, brittleness or tears.
- Make sure the bolts are properly tightened.
- Deformations to the rubber flange or bellows.
- Leaks.
- Condition of the bellows (bulking, hardening, erosions, tears).
- Improper displacement of tie rods.
- Improper movements, displacements and installation lengths.
- Corrosion and wear on the entire component.
- Clean the expansion joints with dilute soap suds and then with clean water. Do not use sharp objects, wire brushes or emery paper.

#### **General guidelines:**

- Do not paint the rubber bellows: solvents will attack the surface and destroy the bellows.
- When welding or cutting, cover the rubber bellows and shield against heat. The anodes and cathodes of the e-weld connection must always be on the same pipe section and may not be separated by an expansion joint.
- Do not insulate the expansion joints.
- It is advisable to make an in-depth inspection every 5 years. It must be accessible for internal inspection or must be dismantled.



Right

Wrong

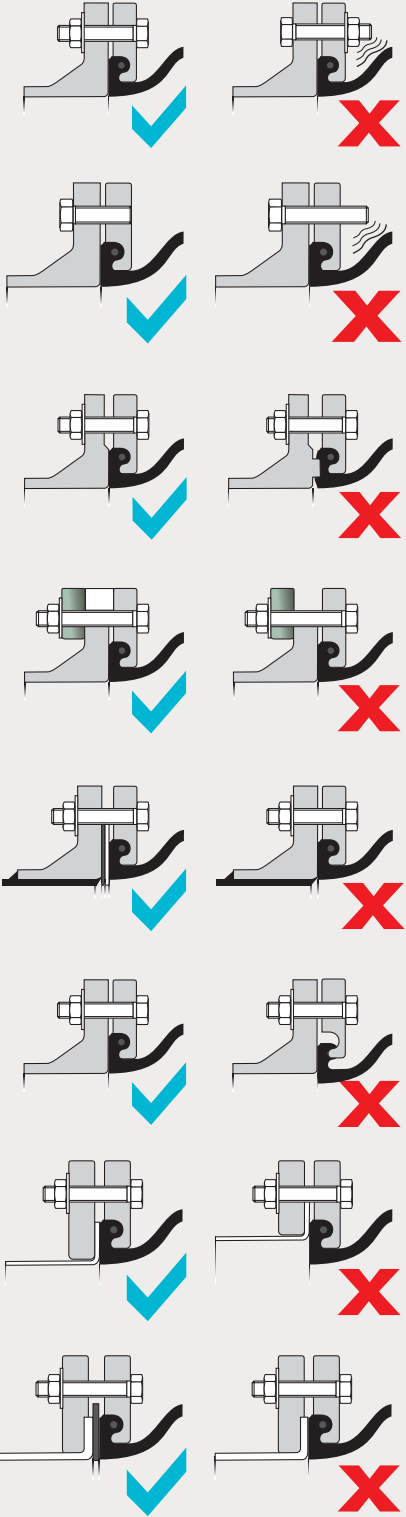

Right

Wrong

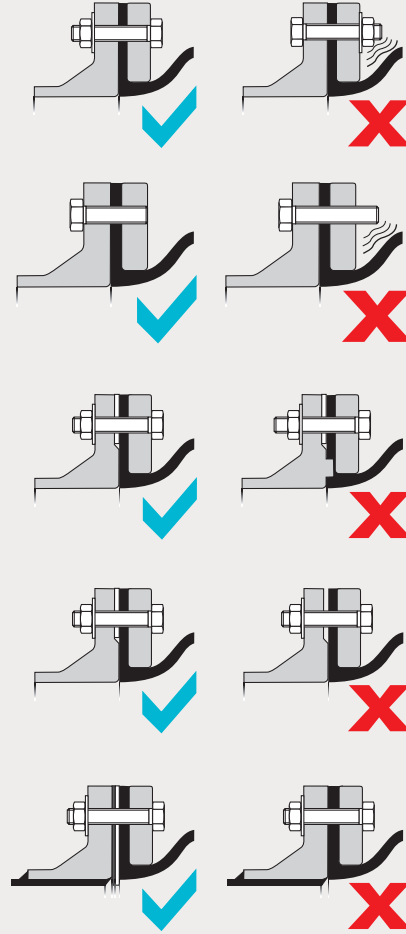

## ON-SITE SERVICE

Expansion Joints require proper handling, storage and installation procedures for optimal performance.

Proper performance of the Expansion Joints is an important factor to insure a safe and reliable system and plant operation. To install and maintain your expansion joints at the highest level, MACOGA offers the most complete after-sales support, including on-site assistance.

MACOGA Site Staff of expert technicians is available on an as-needed basis. Our service teams consist of highly-qualified technicians and engineers specialized in expansion joints.

MACOGA provides a variety of professional on-site assistance to meet your needs.

MACOGA on-site staff can provide you:

- Installation guidance, supervising and technical support during installation
- Inspection during plant shutdown.
- Inspection in service (plant in operation).
- Periodical Inspections
- Maintenance and refurbishment
- Problem resolution
- Immediate response to site inspections needs
- Quick-turn expansion joint replacement during shutdowns and turnarounds
- Assembly and installation of the expansion joints



## CERTIFICATES AND TESTS

### Certificates

- PED (Pressure Equipment Directive) 2014/68/UE
- ISO 9001:2008
- FDA (EPDM DW Drinking Water)
- ATEX Directive upon request. Declaration of Conformity in compliance with the requirements of the ATEX Directive

### Testing

- Hydraulic Pressure Tests
- Tensile strength
- Temperature resistance
- Burst test
- Cycle life test
- Spring rate testing
- Abrasion resistance
- Movement (axial, lateral, angular) testing
- Chemical analysis of the elastomers
- Fluid and chemical compatibility testing
- Electrical properties

MACOGA is fully committed to a quality management process with quality as a foundational business principle. All management



levels participate in quality assurance activities incorporated into daily functional requirements. No product is shipped to the customer until its quality and conformance to customer specifications is assured. Management assesses the effectiveness of the quality system on a regular basis and directs internal efforts towards continuous improvement.





Throughout its more than 40-year history, MACOGA has been a leader in developing technologies and in converting those technologies for use in commercial markets.

Nowadays, MACOGA is one of the largest Expansion Joint manufacturers in the world.

MACOGA is bringing solutions to our customers in more than 80 countries all around the globe and has been synonymous with international focus and worldwide presence for many years.



**MACOGA**  
ENGINEERED EXPANSION JOINTS

Leira. s/n. 15680 Ordes. A Coruña, Spain. Tel: (+34) 981 68 00 00  
[www.macoga.com](http://www.macoga.com) e-mail: [macoga@macoga.com](mailto:macoga@macoga.com)

