

PRODUCT INFORMATION

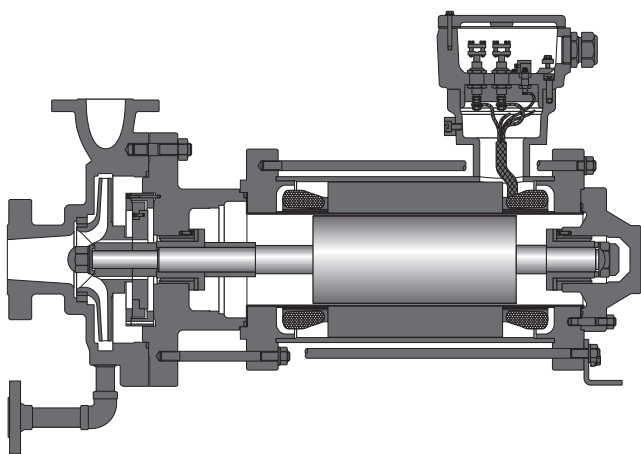

Single-stage canned motor pumps
in process design according to API 685

Model series CNP / CNPF / CNPK

Contents

Description	2
Application and insertion	4
Materials	5
Functional principle	6
Design options	9
Monitoring systems	11
Characteristics diagram	12

Description

General

Canned motor pumps are characterised by a compact, integrated unit without mechanical seal. The motor and pump form a unit with the rotor and the impeller fitted onto a common shaft. The rotor is guided by two identical, medium-lubricated slide bearings. The stator on the drive motor is separated from the rotor space using a thin stator liner. The rotor cavity itself, along with the hydraulic section of the pump, create a combined cavity which needs to be filled with pumping medium before commissioning. The heat loss from the motor is carried off by a partial flow between the rotor and the stator. At the same time, the partial flow lubricates both slide bearings in the rotor cavity. Both the can, which is a hermetically sealed component, and the motor casing are used as a safety containment. Because of that, canned motor pumps always ensure highest safety level when conveying dangerous, toxic, explosive and valuable media.

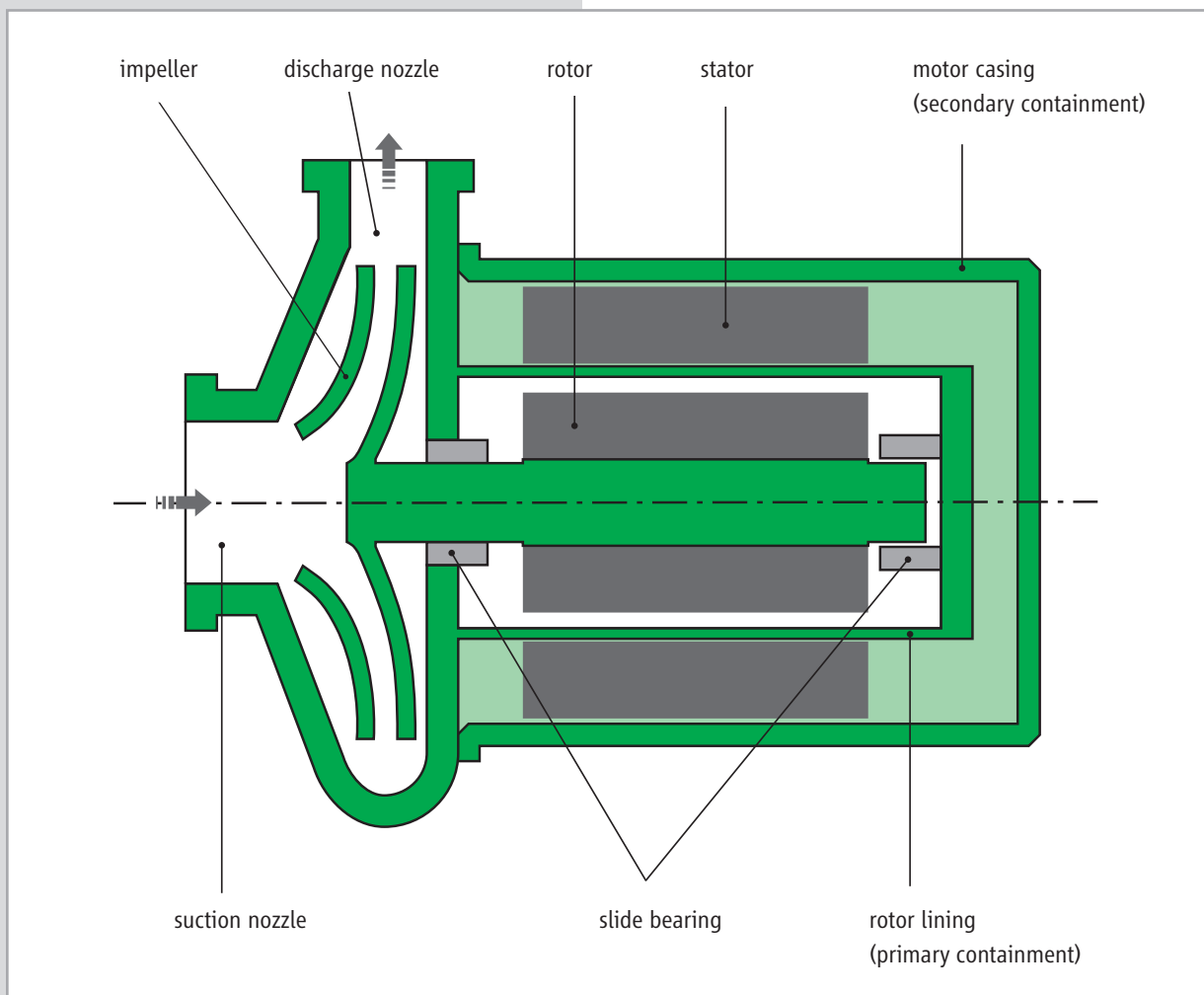

Function

CNP

The partial flow for cooling the motor and lubricating the slide bearings will be branched off at the periphery of the impeller and, after having passed through the motor, is carried back again through the hollow shaft to the suction side of the impeller. This design is suitable for the delivery of uncritical fluids at low vapour pressure values.

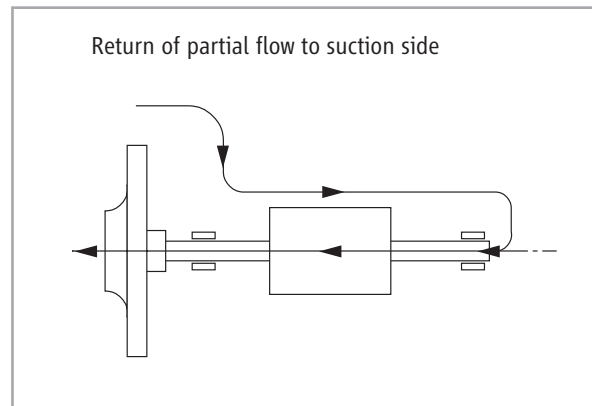

CNPF

The partial flow for cooling the motor and lubricating the slide bearings will be branched off at the periphery of the impeller and, after having passed through the motor, is carried back again to the pressure side. An auxiliary impeller serves to overcome the hydraulic losses encountered along the way. The return of the partial flow towards discharge side ensures that the heated motor cooling flow has sufficient pressure reserves over the boiling point curve of the medium during its return to the pump. This model of pump can be used for liquefied petroleum gases with an extremely steep vapour pressure diagram.

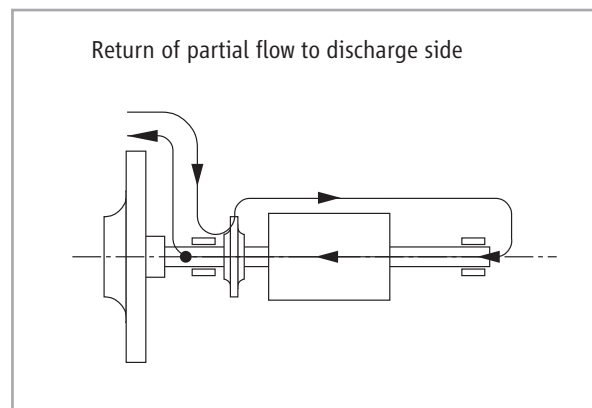

CNPK

The medium is delivered through the suction chamber into the impeller and then through this to the discharge nozzle. A thermal barrier avoids the direct heat transfer from the pump to the motor part. The motor heat loss is dissipated by a secondary cooling-/lubricating circuit via a separate heat exchanger. This cooling-/lubricating circuit also supplies the slide bearings. Thus the fluids at temperature up to +425 °C can be delivered on the discharge side while the secondary cooling cycle is at low temperature level. This construction is also suitable for conveying polluted liquids or liquids charged with solids, if necessary, pure process liquid needs to be dosed into the motor circuit.

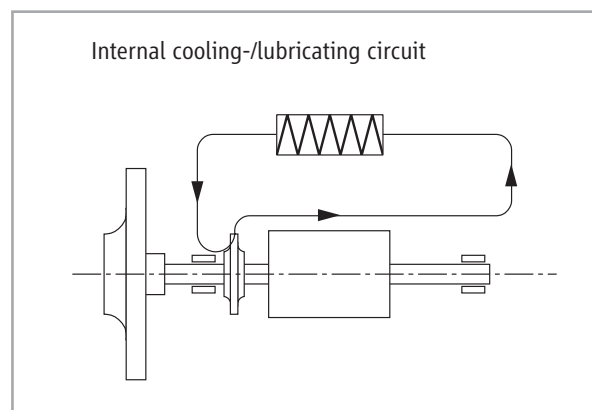

Application and insertion

Application sector

CNP

For the delivery of aggressive, toxic, explosive, precious, inflammable, radioactive and slightly volatile fluids e.g. sulphuric acid, nitric acid, hydrofluoric acid, hydrocyanic acid, ethanoic acid, formic acid, NaOH, KOH, D₂O solvent, etc.

CNPF

- **Liquid gases (LPG):** e.g. propane, butane and their mixtures; chlorine, ammonia, phosgene, etc.
- **Hydrocarbons:** e.g. olefins (ethylene, propylene, etc.), paraffins, aromatic compounds (benzene, toluene, etc.)

CNPK

For the delivery of hot liquids in the vacuum distillation; for the delivery of organic heat transfer oils, as well as heat bath liquids, etc. These models can also be used for aggressive, toxic, explosive, precious, inflammable, radioactive and slightly volatile fluids.

Application ranges

CNP: -120 °C to +360 °C

CNPF: -120 °C to +360 °C

CNPK: -120 °C to +425 °C

Canned motors

Power:	up to 300 kW at 1475 rpm [50 Hz] up to 400 kW at 2950 rpm [50 Hz] up to 336 kW at 1775 rpm [60 Hz] up to 448 kW at 3550 rpm [60 Hz]
Operation:	S1 to S10
Voltage:	400 / 690 V (special tensions possible)
Heat class:	H – 180 C – 220 / C – 400
Frequency:	50 or 60 Hz (plus frequency converter operation on request)
Protections:	motor IP 68 terminal box IP 55
Motor protection:	thermistors e.g. KL 180 (for H-winding) PT 100 (for C-winding)

Pump and hydraulic denomination

e.g.

CNP 100 x 80 x 200 B1

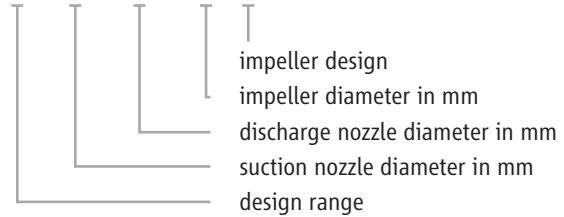

Explosion protection

according to EC design test certificate in line with Directive 94/9/EG ATEX II 2 G EEx de II C T1 to T6 / II 2 G ck II C Tx

Documentation

Digital standard documents (CD-ROM) adapted to CE requirements include:

- sectional drawing
- dimensional drawing
- EC conformity declaration
- operating instructions

Inspections and guarantees

Standard inspections

Hydraulic inspection:

- each pump is subject to a test run and the operating point is guaranteed according to API 685 (5 measuring points)
- pressure test
- axial thrust measurement
- leak test

Additional inspections

The following inspections can be carried out and certified against additional price (e.g. NPSH test, Helium leakage test, vibration test, ultrasonic test, PMI test). Any further inspections and tests are according to the technical specification. The guarantees are effected according to the valid conditions of supply.

Materials

Materials and pressure ratings

VDMA-no.	description	model range CNP / CNPF / CNPK			
		material class S-5 carbon steel	material class S-6 carbon steel / chrome steel	material class C-6 chrome steel	material class A-8 stainless steel
		pressure rating PN 50	pressure rating PN 50	pressure rating PN 50	pressure rating PN 50
wetted parts					
102	volute casing	1.0619	1.0619	1.4317	1.4409
230.01	impeller	1.0619	1.4317	1.4317	1.4409
230.03	auxiliary impeller ⁽¹⁾	JS 1025	1.4408	1.4408	1.4408
472.01/02	slide ring	PTFE/K	PTFE/K	PTFE/K	PTFE/K
502.01	wear ring	1.4028	1.4028	1.4028	1.4404
503.01	impeller wear ring	1.4028	1.4028	1.4028	1.4404
529.01/02	bearing sleeve	1.4571/W5 ⁽²⁾	1.4571/W5 ⁽²⁾	1.4571/W5 ⁽²⁾	1.4571/W5 ⁽²⁾
545.01/02	bearing bush	1.4571/SiC30	1.4571/SiC30	1.4571/SiC30	1.4571/SiC30
816	stator can	Hastelloy C4	Hastelloy C4	Hastelloy C4	Hastelloy C4
817	rotor lining	1.4571	1.4571	1.4571	1.4571
819	motor shaft	1.4021	1.4021	1.4021	1.4571/1.4462
922	impeller nut	1.4571	1.4571	1.4571	1.4571
non-wetted parts					
811	motor casing	1.0254	1.0254	1.0254	1.0254

special materials / higher pressure ratings are possible on demand

(1) parts only for CNPF and CNPK

(2) denotes Tungsten carbide coating

Pressure and temperature limits

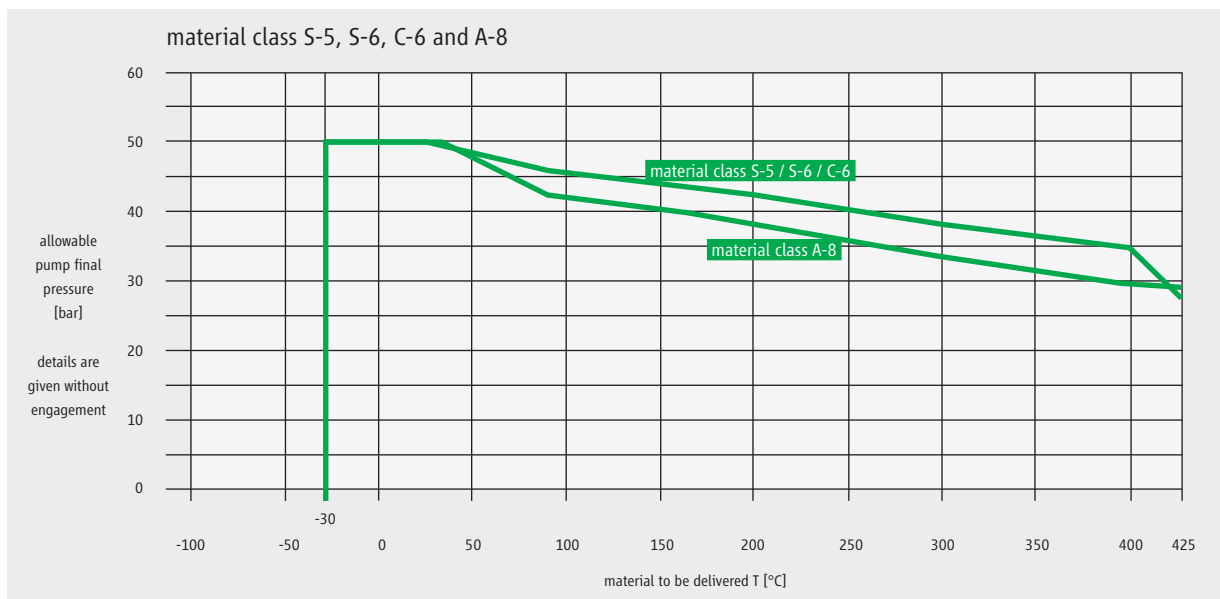

Functional principle

Modular construction principle and functional principle

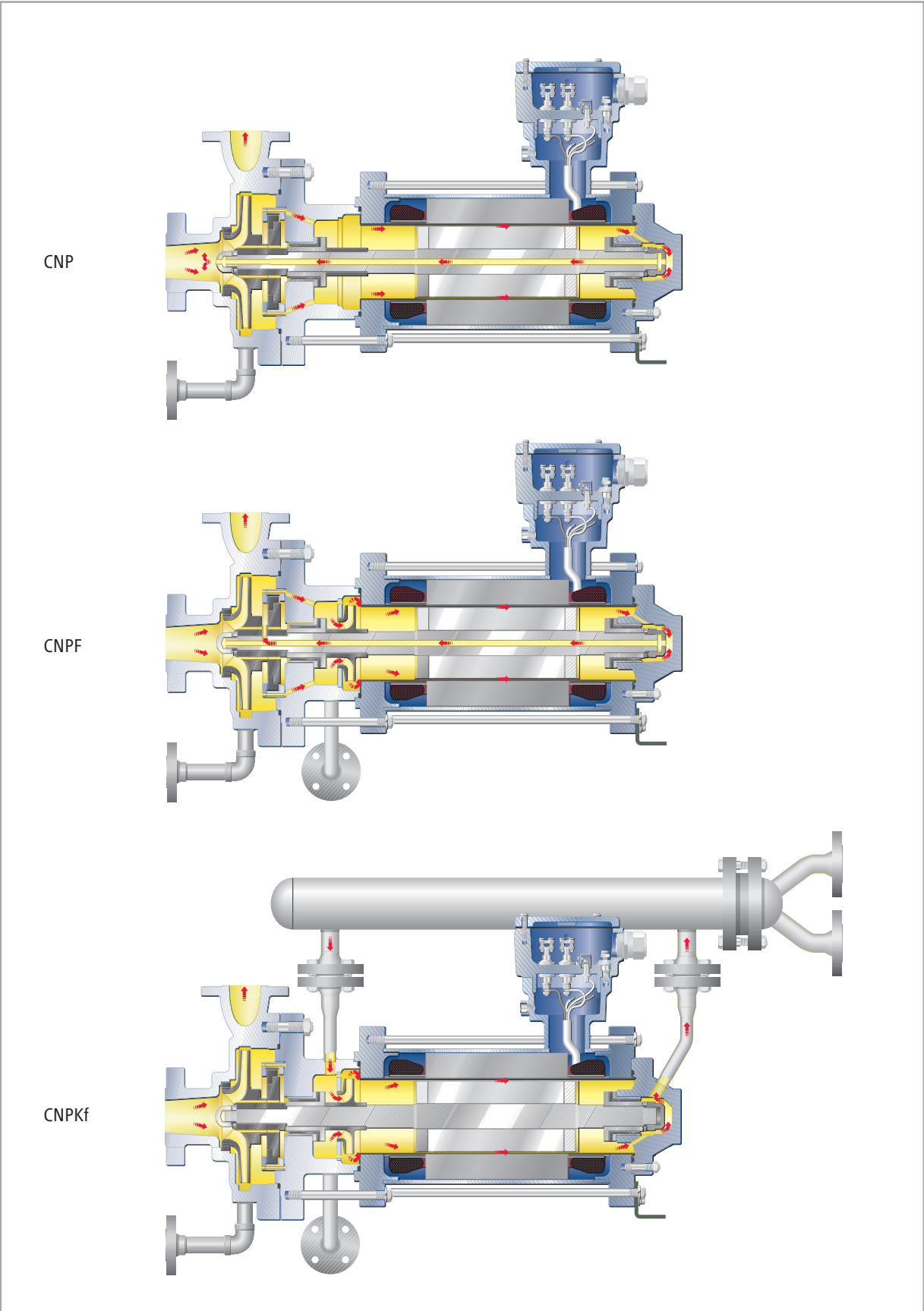

Bearing arrangement

The bearing in hermetically designed pumps must be located and immersed in the operating liquid. Therefore, in most cases, only the use of hydrodynamic slide bearings is required. The correct operating method ensures the advantage that no contact may be created between the bearing lining. Thus, they are constantly running free from wear and maintenance. Service life of 8 to 10 years can be easily achieved by using HERMETIC pumps.

The almost universal bearing combination based on tungsten carbide (W5) and silicon carbide (SiC30) has to be proved to be the best choice. These combinations consist of metallic shaft sleeves made of stainless steel (1.4571) and coated

by tungsten carbide according to the "High Velocity Oxygen Fuel Procedure". Furthermore, they consist of a firm bearing bush made of ceramic material (SiC30) that is surrounded by a sleeve made of stainless steel. SiC30 is a mixed material of silicon carbide and graphite, combining the product advantages of both materials. Conditions of mixed friction, as they may arise for example during start-up and stopping phase of pumps, can be easily handled with SiC30. Moreover, this material is deemed to be thermal shock resistant (high resistance against changes in temperature), as well as chemically stable and blister resistant (no formation of bubbles at material surface) and abrasion resistant.

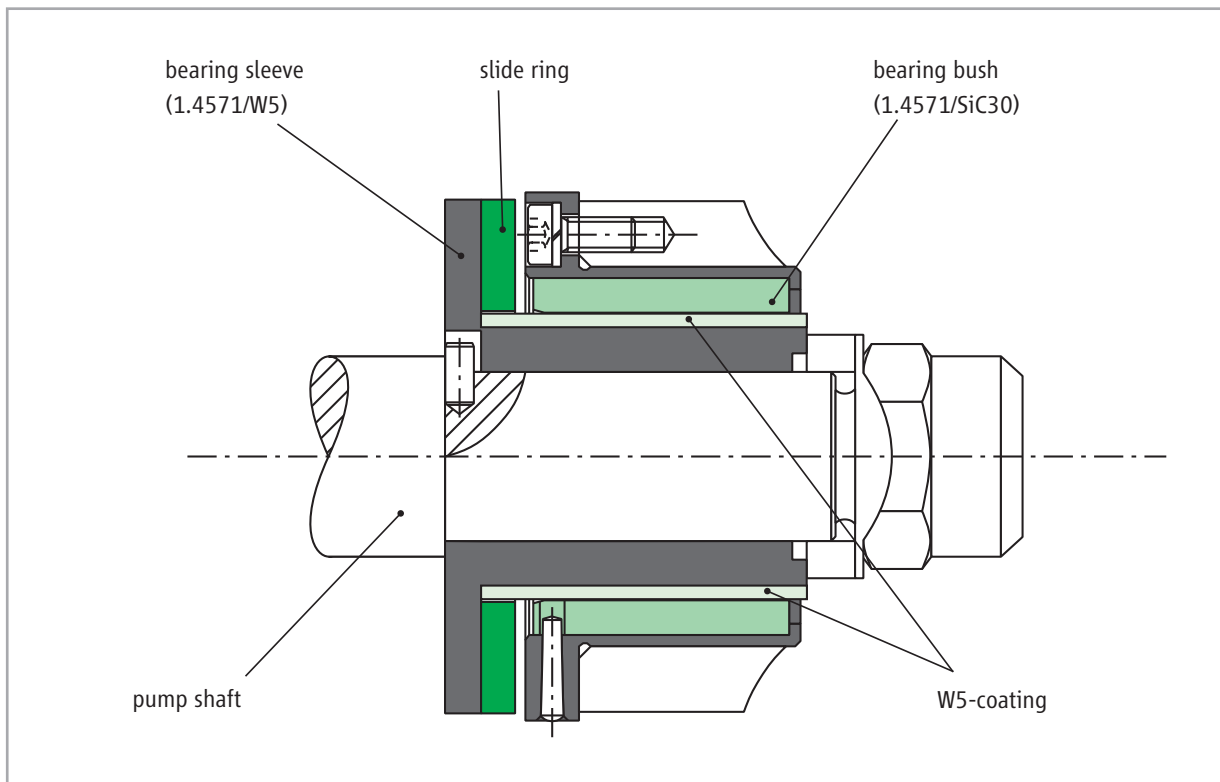

Axial thrust balancing

The development of HERMETIC pump systems depended on the solution of a central problem, namely the elimination of axial thrust at the rotor equipment. The various fluid properties exclude the possibility of using mechanical axial bearings. The only generally valid solution to this problem thus lay in hydraulic balance of the rotor.

The hydraulic balancing device of range CNP / CNPF / CNPK is based on a variable throttling device on the balancing disc. Depending on the rotor's axial position the pressure within

the pressure compensation chamber may change due to the valve effect caused by the variable throttling clearance and thus, it works against the rotor's axial thrust. The pressure within the pressure compensation chamber consequently changes due to the axial position of the rotor. The axial position of the pump shaft is automatically regulated during operation so that a balanced condition is created by itself and thus, there are no effects by axial forces on the axial bearing collar of the slide bearings.

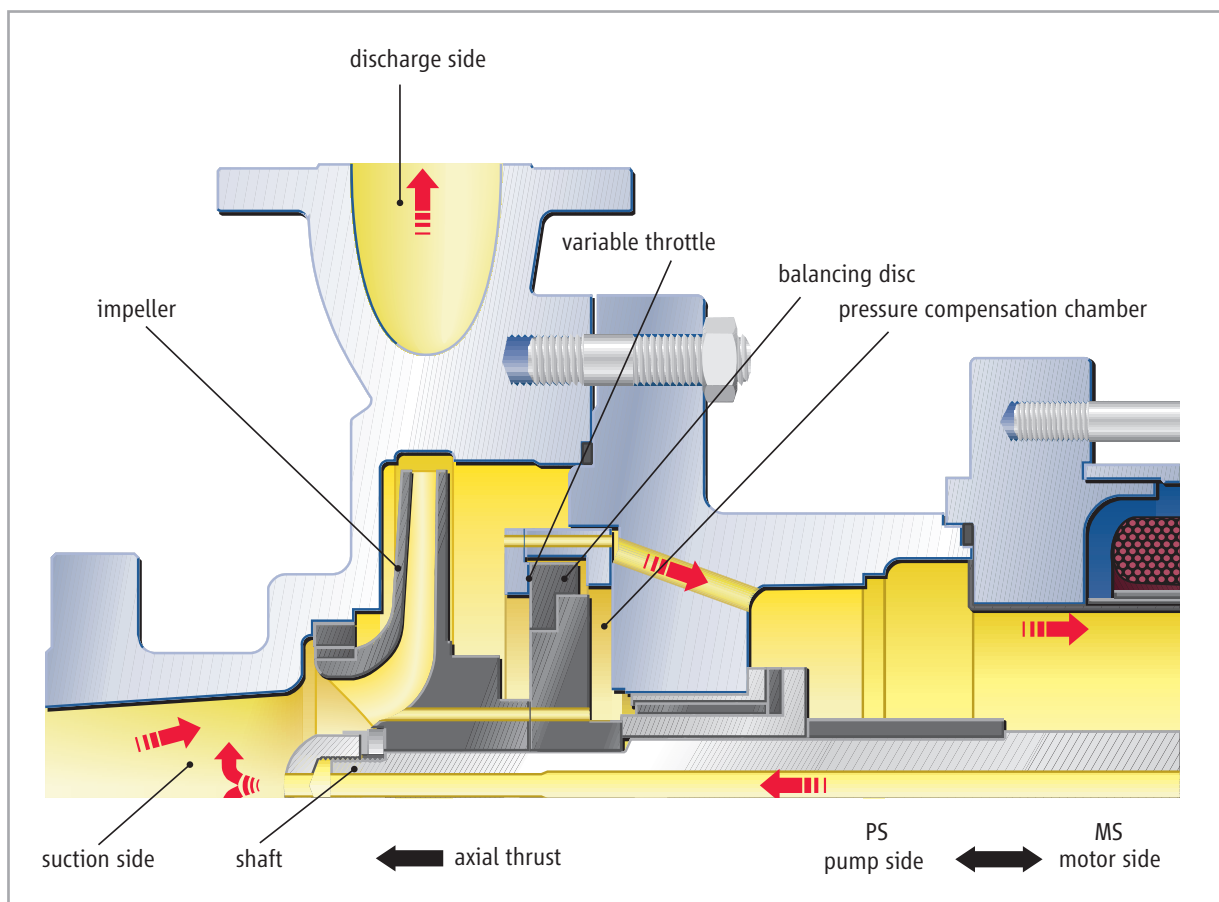

Design options

Medium Duty Design

The centerline-mounted construction with casing according to OH1 (API 610) and flange acc. to ANSI 150 lbs is a feature of this design. This alternative design can be used for each application that do not require a "heavy duty design" according to API 685

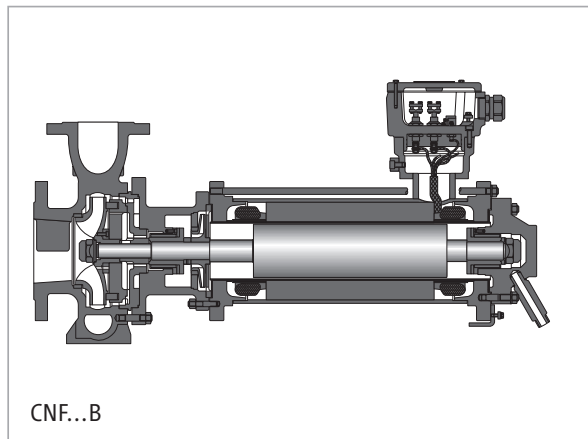

CNF...B

Completely heatable / coolable construction

With heating/cooling jacket on pump casing, motor casing, intermediate lantern and bearing cover. Thus, even liquids with high or different viscosity values (such as, e.g. sulfur, phenol, acrylonitrile) can be conveyed.

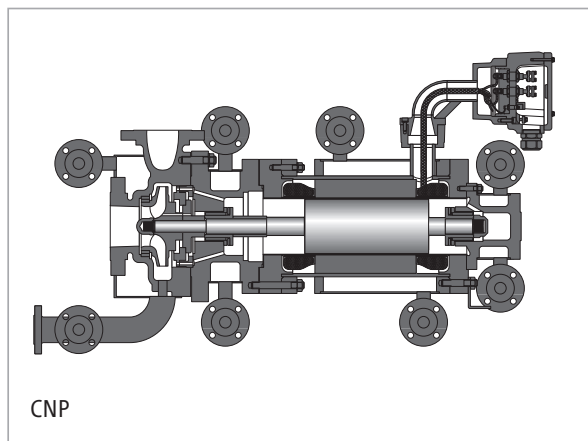

CNP

Top-Top configuration

In case of high-temperature applications, the suction and pressure flange can be designed vertically (the so-called TOP-TOP configuration) according to API requirements. Thus, the tubing can be effected more easily and the number of possibly required tube bends can be reduced.

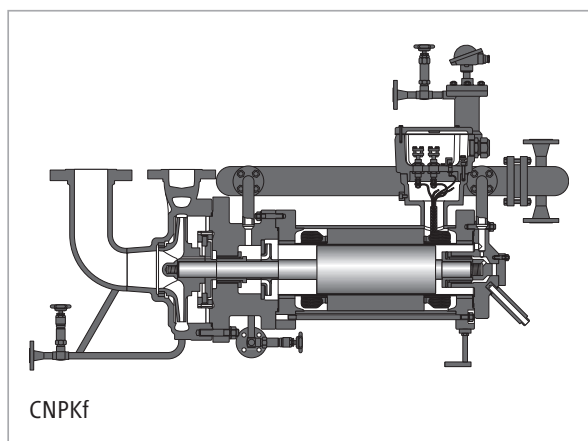

CNPKf

High system pressures

High system pressures (up to 1200 bar) can be handled by canned motor pumps in a technically simple manner. The wall thickness of the outer components corresponds to the required pressure rate.

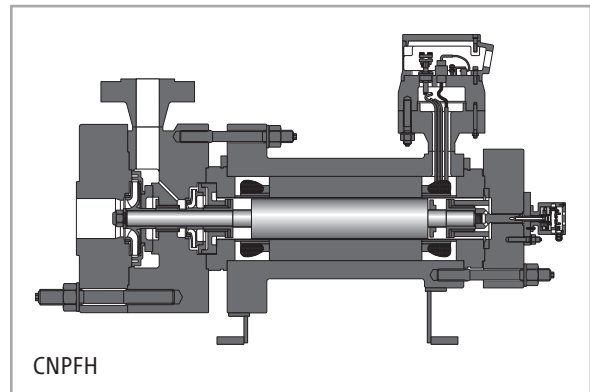

Pressure gases / liquefied gases

Due to the low viscosity and the resulting reduced capacity of the slide bearings, the pump can be erected vertically. In this case, the slide bearings do not have support properties, but only a leading function. The rotor weight is hydrostatically supported here.

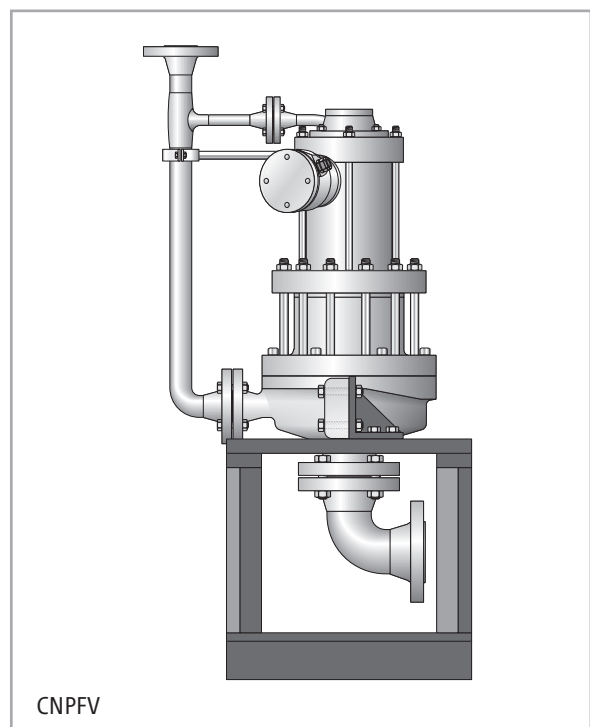

Monitoring systems

The most part of HERMETIC pumps are designed according to explosion protection requirements. The pumps comply with the requirements of the electrical as well as mechanical explosion protection.

Level monitoring

On condition that the rotor cavity as part of the process system is steadily filled with liquid, no explosive atmosphere may arise. In this case, no accepted explosion protection is required for the rotor cavity. If the operator is not able to guarantee for a steady filling, it is necessary to install level monitoring devices.

Temperature monitoring

The observance of the temperature class and the maximum admissible surface temperature of the canned motor, respectively, is ensured via thermistor in the stator winding and/or via a measuring point on the bearing cover (liquid temperature).

Monitoring of rotor position

The axial thrust balancing is mainly influenced by the operating method of the pump, plant conditions and by various physical data of the liquid to be conveyed. For early detection of the source of errors, it is recommended to install a rotor-position-monitoring device. This electronic protective gear monitors the axial shaft clearance of the rotor, as well as its direction of rotation during operation in a hermetic and seal-less way. Together with the level and temperature monitoring, an effective and automatic early detection of failures may be achieved.

various monitoring devices

①	Type FTL 50/51	LI	level
②	Type O 30	LS	
③	Type KL 180	TS	temperature
④	Type PT 100	TI	
⑤	Type ARM-2000 (4...20mA)	GI	rotor position/ direction of rotation
⑥	Type AM-2000	GI	rotor position
⑦	Type MAP	GI	rotor position
⑧	Type ROM	GI	direction of rotation

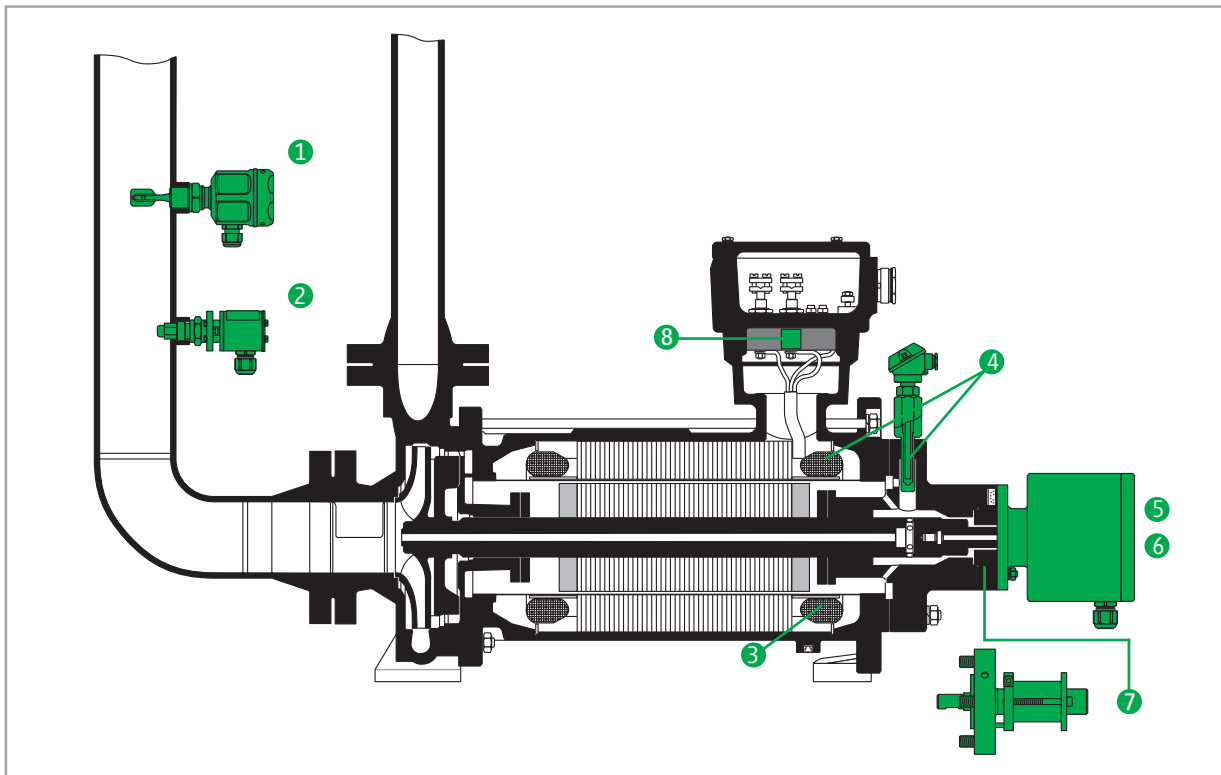

Characteristics diagram

Characteristics diagram 2950 rpm 50 Hz

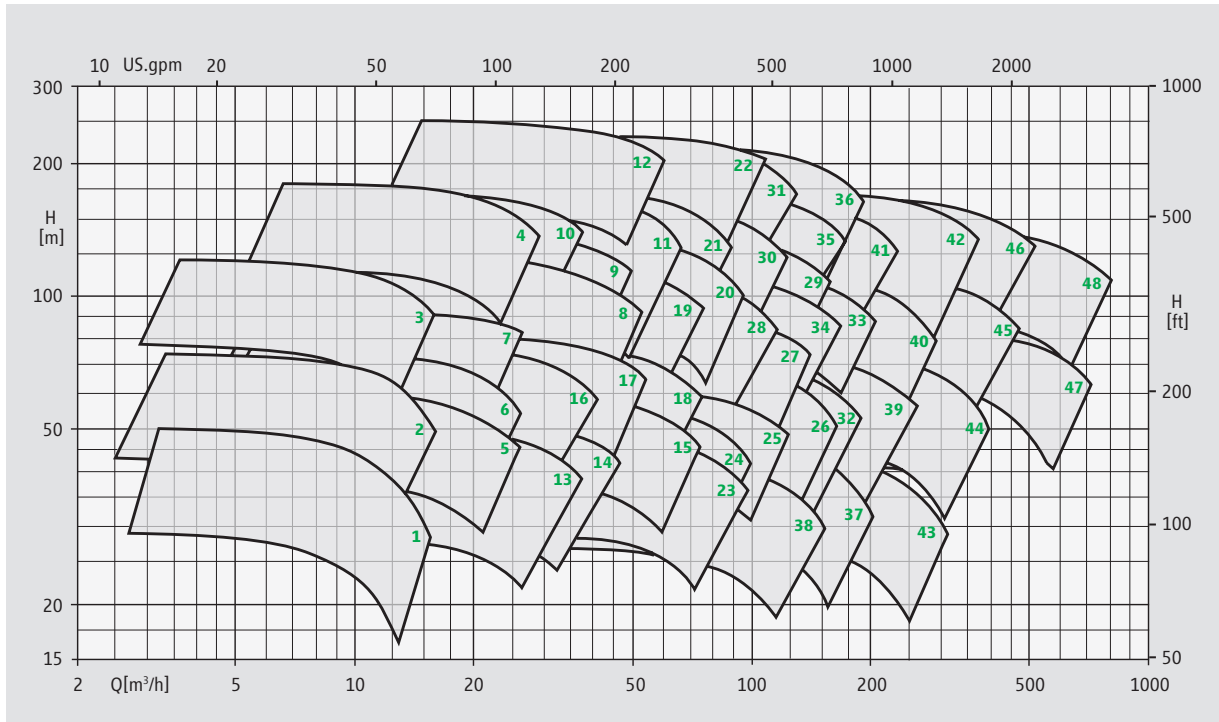

Denomination of hydraulics to the characteristics diagram

1 50x25x190	12 100x40x400	23 100x80x190	34 150x80x290B	45 200x150x290
2 50x25x230	13 80x50x190A	24 100x80x200A	35 150x80x350	46 200x150x350A
3 80x25x290	14 80x50x190B	25 100x80x200B	36 150x80x400	47 200x200x250
4 100x25x350	15 80x50x200	26 100x80x230	37 150x100x190A	48 200x200x320
5 80x40x200	16 80x50x230A	27 100x80x250	38 150x100x190B	
6 80x40x230	17 80x50x230B	28 100x80x290	39 150x100x230	
7 80x40x250	18 100x50x230	29 100x80x320	40 150x100x290	
8 80x40x290	19 100x50x290	30 100x80x350	41 150x100x350A	
9 80x40x320	20 100x50x320	31 100x80x430	42 150x100x350B	
10 100x40x350A	21 100x50x350	32 150x80x230	43 150x150x190	
11 100x40x350B	22 100x50x400	33 150x80x290A	44 150x150x230	

Characteristics diagram 1475 rpm 50 Hz

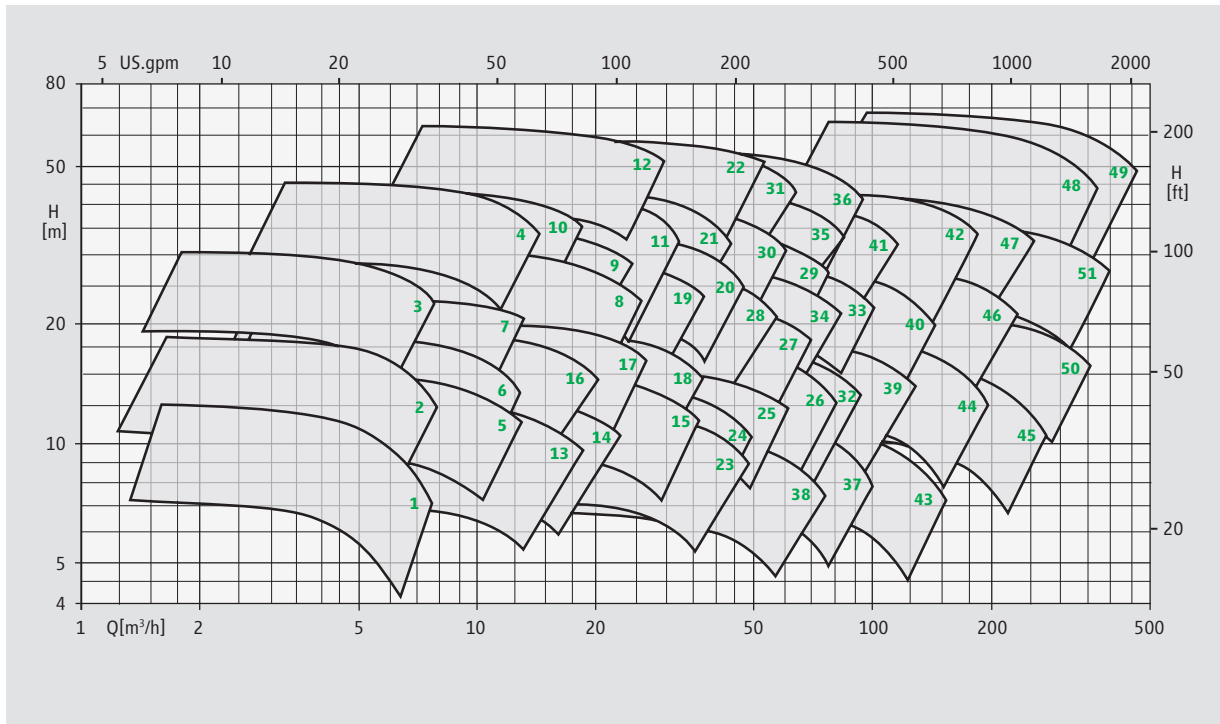

Denomination of hydraulics to the characteristics diagram

1 50x25x190	12 100x40x400	23 100x80x190	34 150x80x290B	45 200x150x230
2 50x25x230	13 80x50x190A	24 100x80x200A	35 150x80x350	46 200x150x290
3 80x25x290	14 80x50x190B	25 100x80x200B	36 150x80x400	47 200x150x350A
4 100x25x350	15 80x50x200	26 100x80x230	37 150x100x190A	48 200x150x430A
5 80x40x200	16 80x50x230A	27 100x80x250	38 150x100x190B	49 200x150x430B
6 80x40x230	17 80x50x230B	28 100x80x290	39 150x100x230	50 200x200x250
7 80x40x250	18 100x50x230	29 100x80x320	40 150x100x290	51 200x200x320
8 80x40x290	19 100x50x290	30 100x80x350	41 150x100x350A	
9 80x40x320	20 100x50x320	31 100x80x430	42 150x100x350B	
10 100x40x350A	21 100x50x350	32 150x80x230	43 150x150x190	
11 100x40x350B	22 100x50x400	33 150x80x290A	44 150x150x230	

Characteristics diagram 3550 rpm 60 Hz

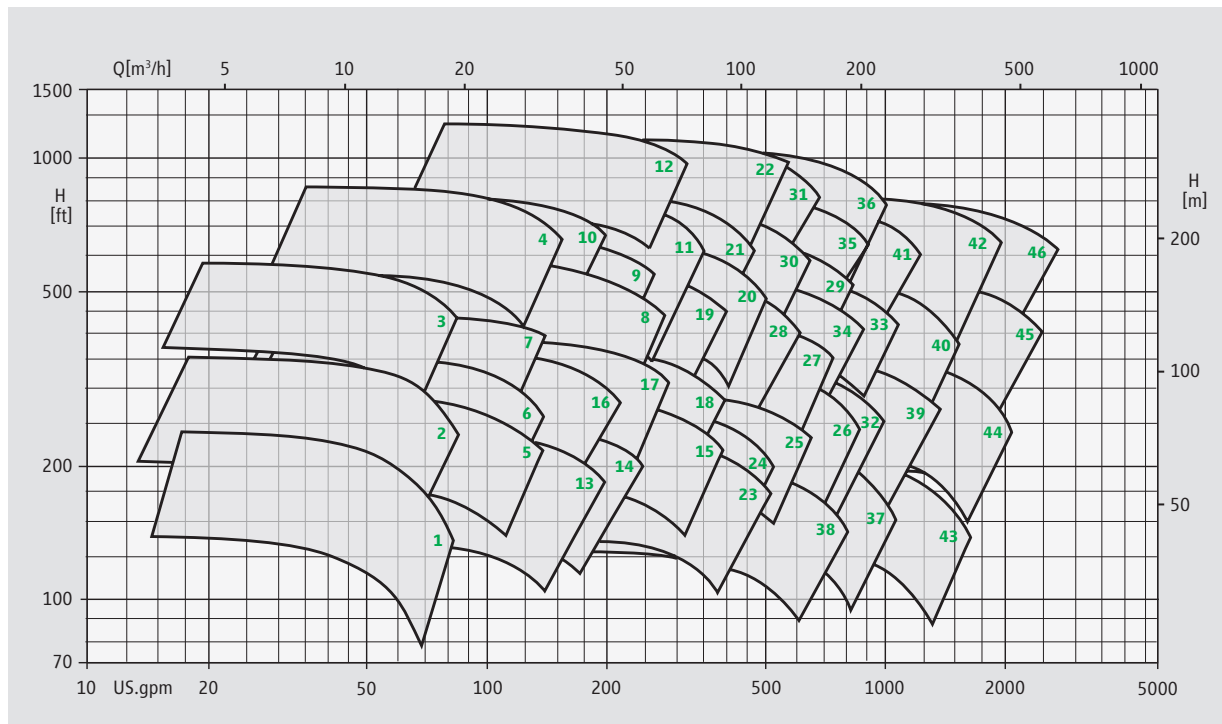

Denomination of hydraulics to the characteristics diagram

1 50x25x190	12 100x40x400	23 100x80x190	34 150x80x290B	45 200x150x290
2 50x25x230	13 80x50x190A	24 100x80x200A	35 150x80x350	46 200x150x350A
3 80x25x290	14 80x50x190B	25 100x80x200B	36 150x80x400	
4 100x25x350	15 80x50x200	26 100x80x230	37 150x100x190A	
5 80x40x200	16 80x50x230A	27 100x80x250	38 150x100x190B	
6 80x40x230	17 80x50x230B	28 100x80x290	39 150x100x230	
7 80x40x250	18 100x50x230	29 100x80x320	40 150x100x290	
8 80x40x290	19 100x50x290	30 100x80x350	41 150x100x350A	
9 80x40x320	20 100x50x320	31 100x80x430	42 150x100x350B	
10 100x40x350A	21 100x50x350	32 150x80x230	43 150x150x190	
11 100x40x350B	22 100x50x400	33 150x80x290A	44 150x150x230	

Characteristics diagram 1775 rpm 60 Hz

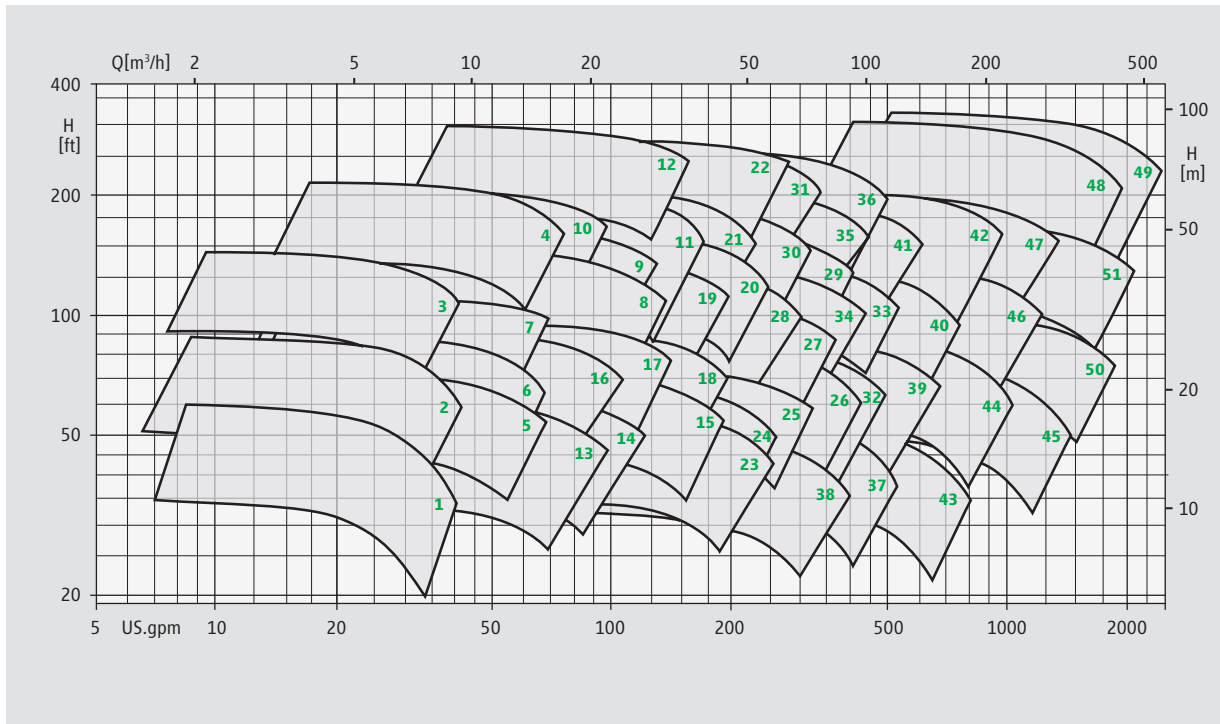

Denomination of hydraulics to the characteristics diagram

1 50x25x190	12 100x40x400	23 100x80x190	34 150x80x290B	45 200x150x230
2 50x25x230	13 80x50x190A	24 100x80x200A	35 150x80x350	46 200x150x290
3 80x25x290	14 80x50x190B	25 100x80x200B	36 150x80x400	47 200x150x350A
4 100x25x350	15 80x50x200	26 100x80x230	37 150x100x190A	48 200x150x430A
5 80x40x200	16 80x50x230A	27 100x80x250	38 150x100x190B	49 200x150x430B
6 80x40x230	17 80x50x230B	28 100x80x290	39 150x100x230	50 200x200x250
7 80x40x250	18 100x50x230	29 100x80x320	40 150x100x290	51 200x200x320
8 80x40x290	19 100x50x290	30 100x80x350	41 150x100x350A	
9 80x40x320	20 100x50x320	31 100x80x430	42 150x100x350B	
10 100x40x350A	21 100x50x350	32 150x80x230	43 150x150x190	
11 100x40x350B	22 100x50x400	33 150x80x290A	44 150x150x230	

Convincing service.

Important features are readiness, mobility, flexibility, availability and reliability. We are anxious to ensure a pump operation at best availability and efficiency to our customers.

Installation and commissioning

- service effected on site by own service technicians

Spare part servicing

- prompt and longstanding availability
- customized assistance in spare part stockkeeping

Repair and overhauling

- professional repairs including test run executed by the parent factory
- or executed by one of our service stations worldwide

Maintenance and service agreement

- concepts individually worked out to increase the availability of your production facilities

Training and workshops

- extra qualification of your staff to ensure the course of your manufacture

Our products comply with:

- Explosion protection acc. to ATEX / UL / CQST / CSA
- VOC directive 1999/13/EC
- TA-Luft
- IPPC directive
- CE
- RCCM, level 2
- Rosgortechnazdor

HERMETIC-Pumpen GmbH is certified acc. to:

- ISO 9001:2000
- GOST "R"
- ATEX 94/9/EG
- AD HP 0 / TRD 201
- DIN EN 729-2
- KTA 1401, QSP 4a