

PRODUCT INFORMATION

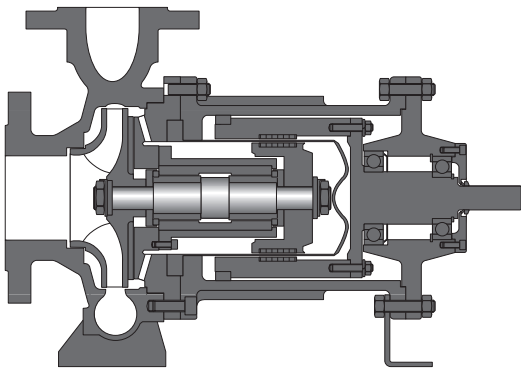

Single-stage magnetically coupled  
pumps according to  
EN 22858; ISO 2858; ISO 5199

Model series MCN

## Contents \_\_\_\_\_

Description .....	2
Application and insertion .....	4
Materials .....	5
Functional principle .....	6
Monitoring systems .....	9
Characteristics diagram .....	10

## Description \_\_\_\_\_

### General

Hermetically sealed pumps with magnetic coupling are characterized by a single-acting safety sleeve. The separation of liquid to the atmosphere is effected via the so-called containment shell. As it is the case with conventional centrifugal pumps with mechanical seal, a common standard motor is used which one is combined with the magnetic drive through a coupling for the drive of the pump. The outer rotor contains permanent magnets transferring the turning moment created by the motor via the containment shell to the inner rotor.

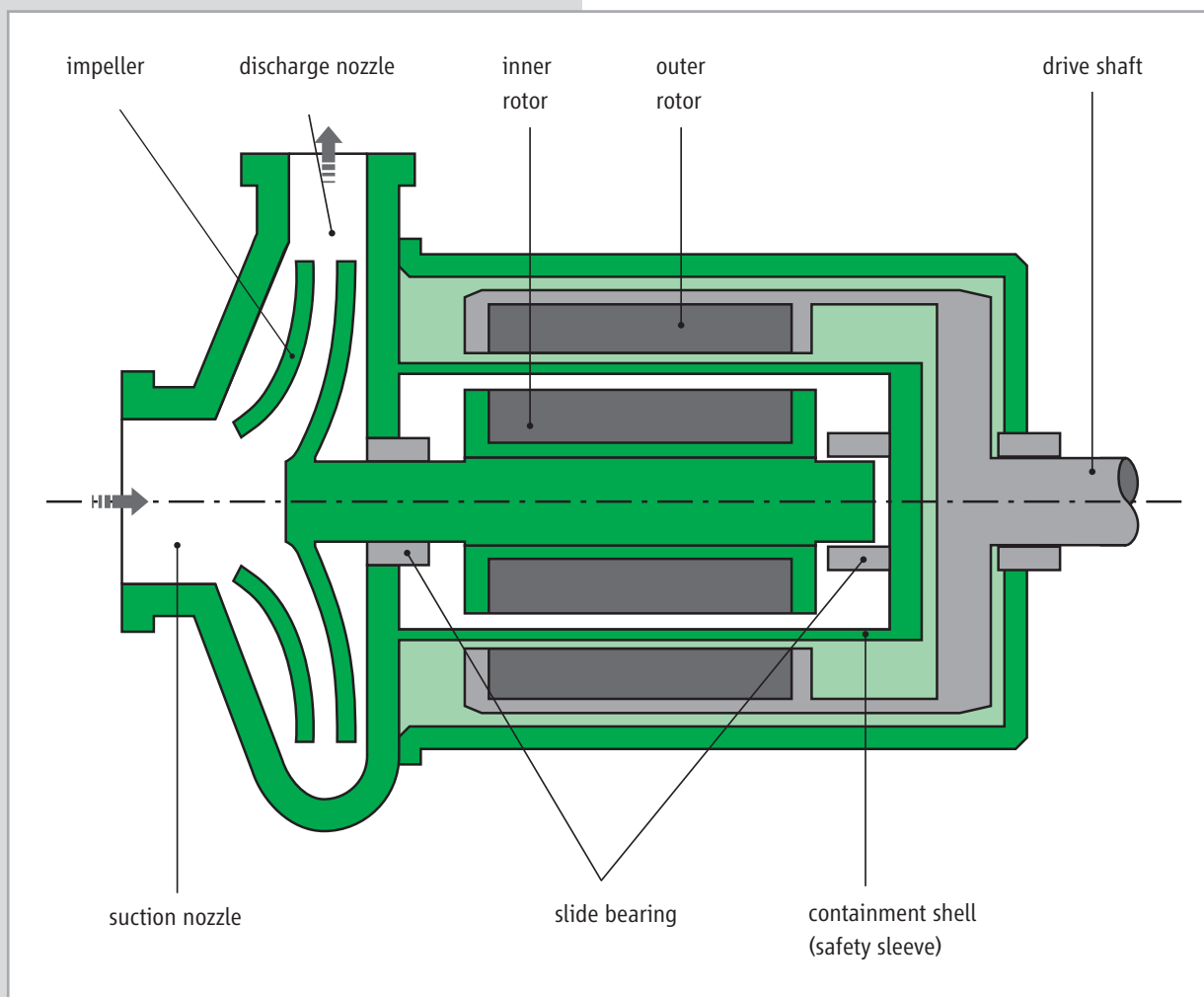

### Function

#### MCNn / MCNn close-coupled

The medium being pumped runs via the suction chamber into the impeller and is conveyed by the impeller to the discharge nozzle. The slide bearings are lubricated and the rotor compartment is cooled via the partial flow which has been taken from the main pump flow and which is returned to the main flow after moving through the can and the hollow shaft. Part of the partial flow is conveyed to the suction side of the impeller and another part is conveyed through the hollow shaft to the discharge side. The design is suitable for the convey of uncritical liquids at low vapour pressure values.

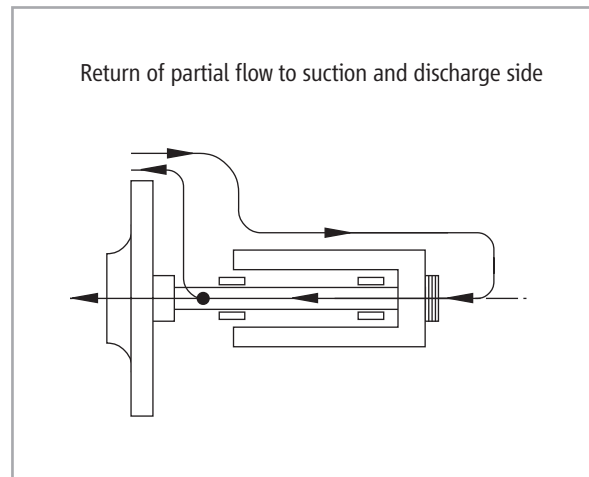

#### MCN / MCN close-coupled

The medium being pumped runs via the suction chamber into the impeller and is conveyed by the impeller to the discharge nozzle. The slide bearings are lubricated and the rotor compartment is cooled via the partial flow which has been taken from the main pump flow and which is returned to the main flow after moving through the can and the hollow shaft to the suction side of the impeller. This design is suitable for conveying uncritical liquids at low vapour pressure values.

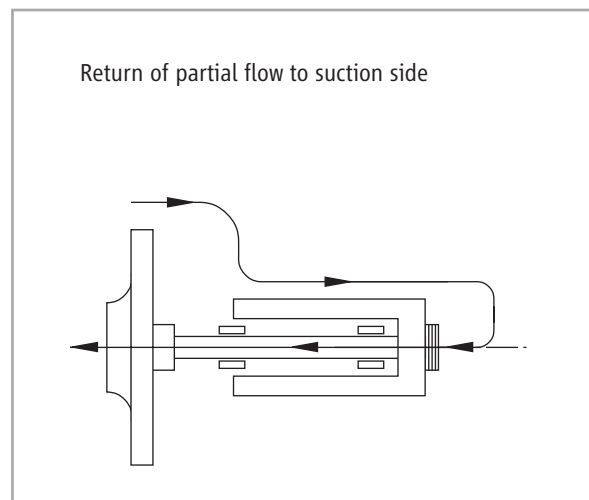

#### MCNF / MCNF close-coupled

The medium being pumped runs via the suction chamber into the impeller and is conveyed by the impeller to the discharge nozzle. The slide bearings are lubricated and the rotor compartment is cooled via the partial flow which has been taken from the main pump flow and which is returned to the main flow after moving through the hollow shaft and the containment shell back to the discharge side. Additional radial borings on rotor end serves to overcome the hydraulic losses encountered along the way. The partial flow return to the discharge side means that there is always sufficient reserve pressure available from the boiling point curve of the medium being conveyed when the heated motor cooling flow returns to the pump. This model of pump can be used for liquefied petroleum gases as well when the same conditions are available.

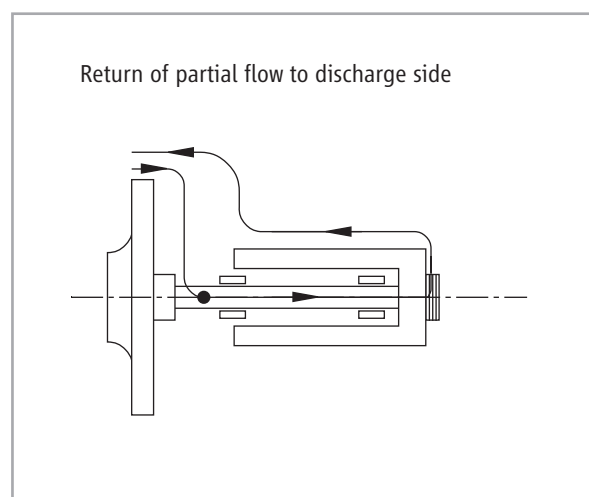

# Application and insertion

---

## Design

The construction and ratings scheme of the pumps conform to EN 22858 / ISO 2858 / ISO 5199 and have a permanent magnetic coupling as an integral component. The required output is transferred to the pump via a conventional standard three phase current motor of type B 3 or B 35 with the corresponding intermediate coupling.

## Application sector

For the delivery of aggressive, toxic, explosive, precious, inflammable and slightly volatile fluids.

## Application ranges

MCNn:	-40 °C to +220 °C (350 °C)*
MCN:	-40 °C to +220 °C (350 °C)*
MCNF:	-40 °C to +220 °C (350 °C)*
MCNn close-coupled:	-40 °C to +100 °C **
MCN close-coupled:	-40 °C to +100 °C **
MCNF close-coupled:	-40 °C to +100 °C **

\* with thermal break MCNnK (high temperature design)

\*\*  $\geq 100$  °C on request

## Magnetic drive

Thanks to the use of new types of permanent magnetic materials with high energy density, it is possible to house a powerful magnetic coupling within the pump bearing support specified in the standard. The magnetic drive is equipped for direct activation when operated using standard three phase current motors and does not require any type of coupling. In addition, the permanent magnets are highly stable against demagnetising effects, such as those which may occur when assembling or disassembling the rotor or if the maximum transmittable torque is exceeded.

Power:

- up to 70 kW at 1450 rpm
  - up to 58 kW at 2900 rpm
- (larger ratings are possible on demand)

## Explosion protection

according to EC design test certificate in line with Directive 94/9/EG ATEX  II 2 G c T2 to T6

## Documentation

Digital standard documents (CD-ROM) adapted to CE requirements include:

- sectional drawing
- dimensional drawing
- EC conformity declaration
- operating instructions

## Inspections and guarantees

### Standard inspections

Hydraulic inspection:

- each pump is subject to a test run and the operating point is guaranteed according to ISO 9906 – class 2 (5 measuring points)
- pressure test
- leak test

### Additional inspections

The following inspections can be carried out and certified against additional price (e.g. NPSH test, Helium leakage test, vibration test, ultrasonic test, PMI test). Any further inspections and tests are according to the technical specification. The guarantees are effected according to the valid conditions of supply.

# Materials

## Materials and pressure ratings

VDMA-no.	description	model range MCNn / MCN / MCNF		
		material S1	material S2	material C
		pressure rating PN 25	pressure rating PN 25	pressure rating PN 16
102	volute casing	JS 1025	1.0619+N	1.4408
161	casing cover	1.0570	1.0570	1.4571 / 1.0570
211	pump shaft	1.4571 / 1.4462	1.4571 / 1.4462	1.4571 / 1.4462
213	magnet assembly	1.0254 / JS 1025	1.0254 / JS 1025	1.0254 / JS 1025
230	impeller	JL 1040	JL 1040	1.4408
381	bearing insert	1.4571	1.4571	1.4571
473	slide ring	S-SiC	S-SiC	S-SiC
529	bearing sleeve	S-SiC	S-SiC	S-SiC
545	bearing bush	S-SiC	S-SiC	S-SiC
817	containment shell	2.4610	2.4610	2.4610
818	rotor	1.4571	1.4571	1.4571

special materials / higher pressure ratings are possible on demand

## Pressure and temperature limits

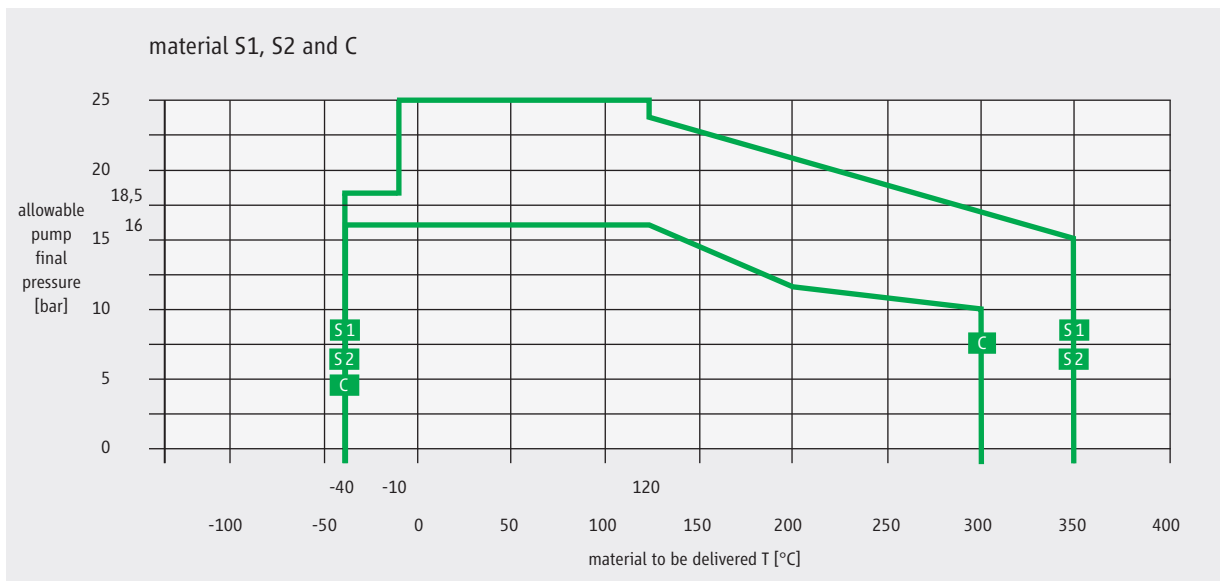

# Functional principle

*Magnetically coupled pump in bearing bracket design*

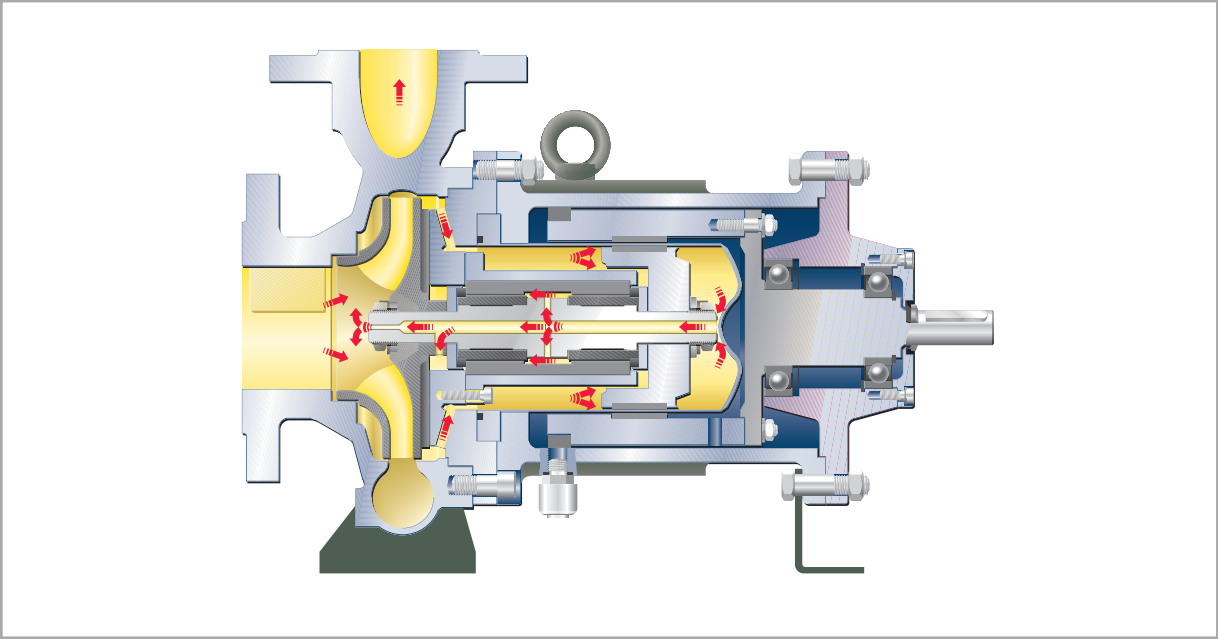

*Magnetically coupled pump in close-coupled design*

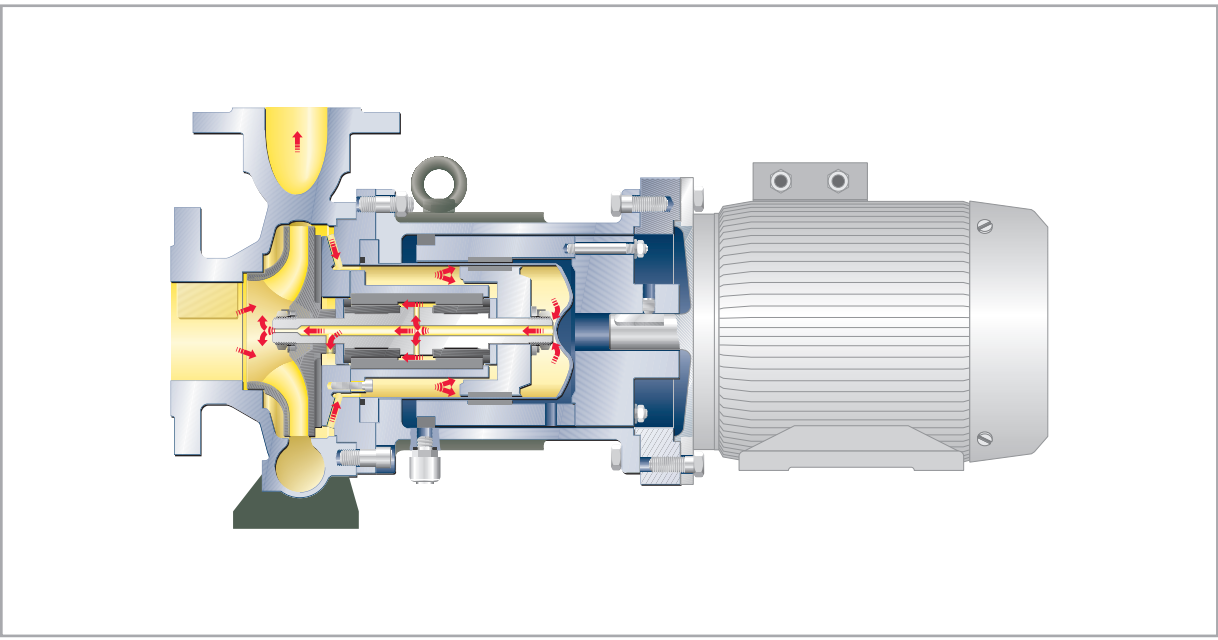

### Bearing arrangement

The bearing in hermetically designed pumps must be located and immersed in the operating liquid. Therefore, in most cases, only the use of hydrodynamic slide bearings is required. The correct operating method ensures the advantage that no contact may be created between the bearing lining. Thus, they are constantly running free from wear and maintenance. Service life of 8 to 10 years can be easily achieved by using HERMETIC pumps.

As a standardised bearing combination the material based on silicone carbide - silicone carbide has proved to be the best choice. This combination consists of a bearing sleeve made of silicone carbide (S-SiC) and a firm bearing bush made of the material S-SiC/1.4571. S-SiC is a pressureless sintered silicone carbide which is characterised by its high resistance against high temperatures and corrosion. Conditions of mixed friction, as they may arise for example during start-up and stopping phase of pumps, can be easily handled with this bearing combination.

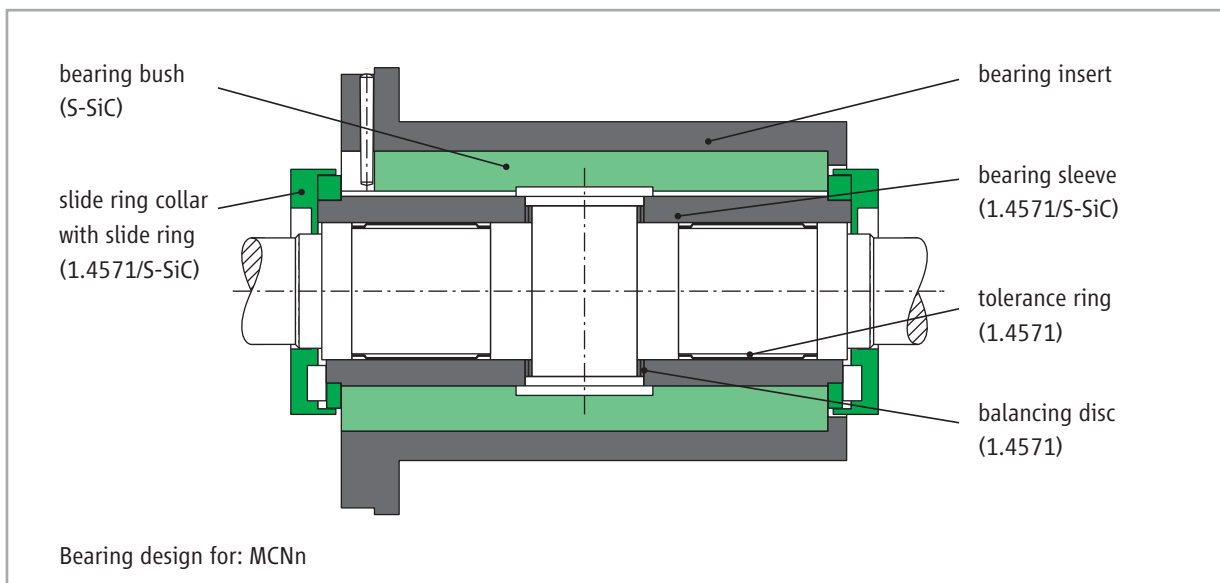
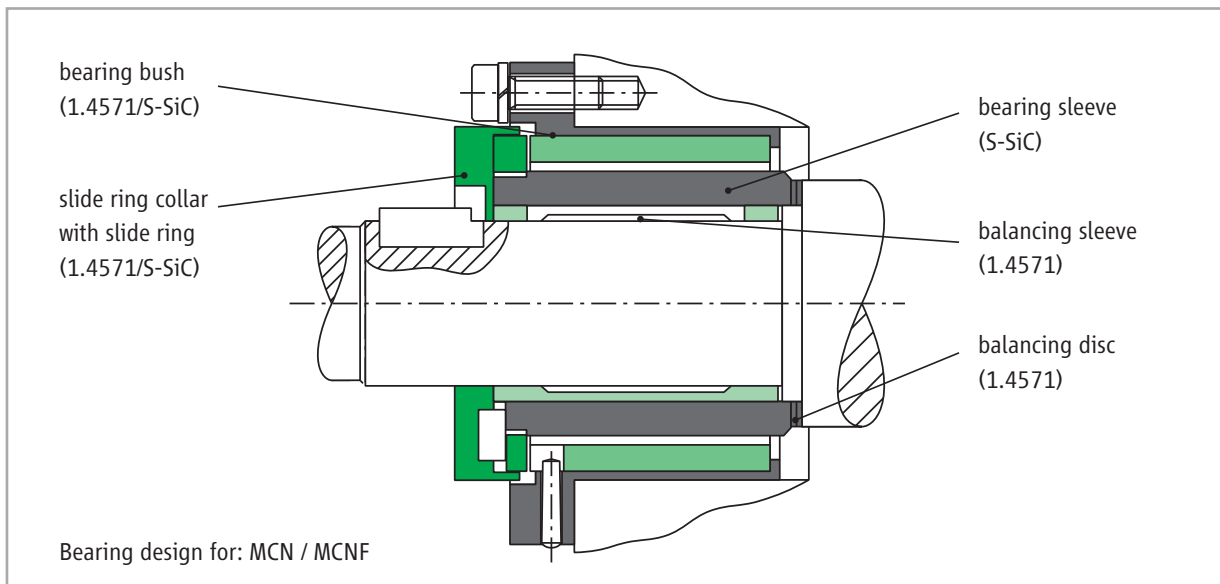

### Axial thrust balancing

The development of HERMETIC pump systems depended on the solution of a central problem, namely the elimination of axial thrust at the rotor equipment. The various fluid properties exclude the possibility of using mechanical axial bearings. The only generally valid solution to this problem thus lay in hydraulic balance of the rotor.

The functional principle of the hydraulic balancing device of range MCN is based on a reduction in pressure behind the impeller caused by the back vanes. The pressure on back side of the impeller changes together with the axial position of the rotor.

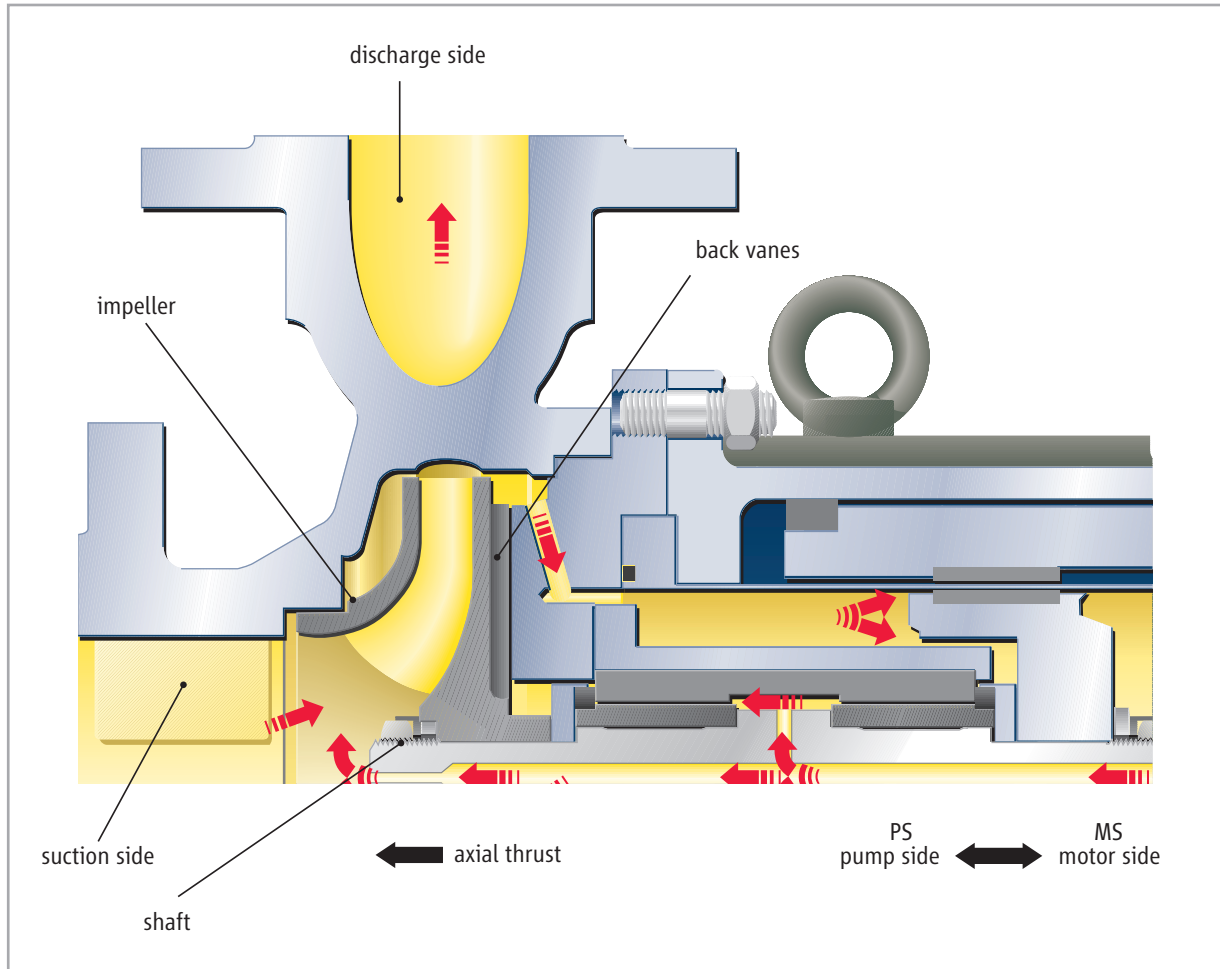



# Monitoring systems

The most part of HERMETIC pumps are designed according to explosion protection requirements. The pumps comply with the requirements of the electrical as well as mechanical explosion protection.

### Level monitoring

On condition that the rotor cavity as part of the process system is steadily filled with liquid, no explosive atmosphere may arise. In this case, no accepted explosion protection is required for the rotor cavity. If the operator is not able to guarantee for a steady filling, it is necessary to install level monitoring devices.

### Temperature monitoring

The observance of the temperature class and the maximum admissible surface temperature is ensured by a measuring point on the containment shell (liquid temperature).

various monitoring devices			
①	Type N 30	LS	level
②	Type O 30	LS	
③	Type PT 100	TI	temperature

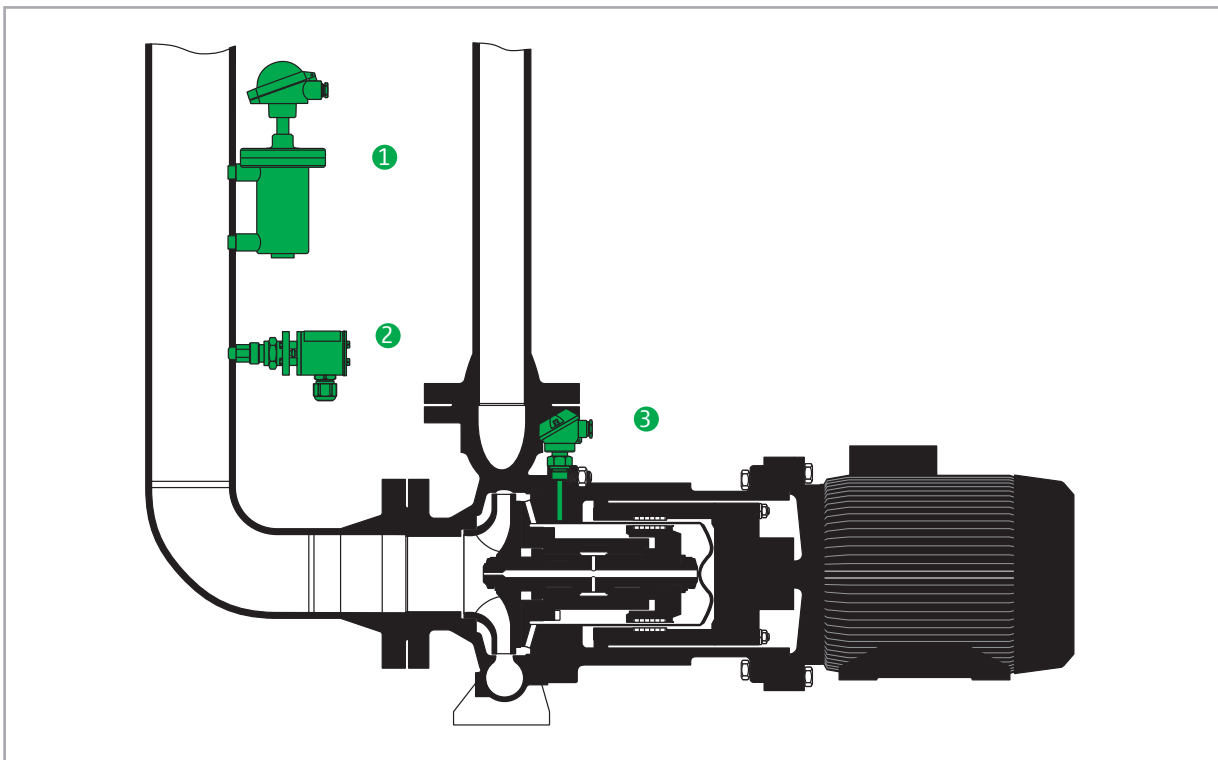

# Characteristics diagram

Characteristics diagram 2900 rpm 50 Hz

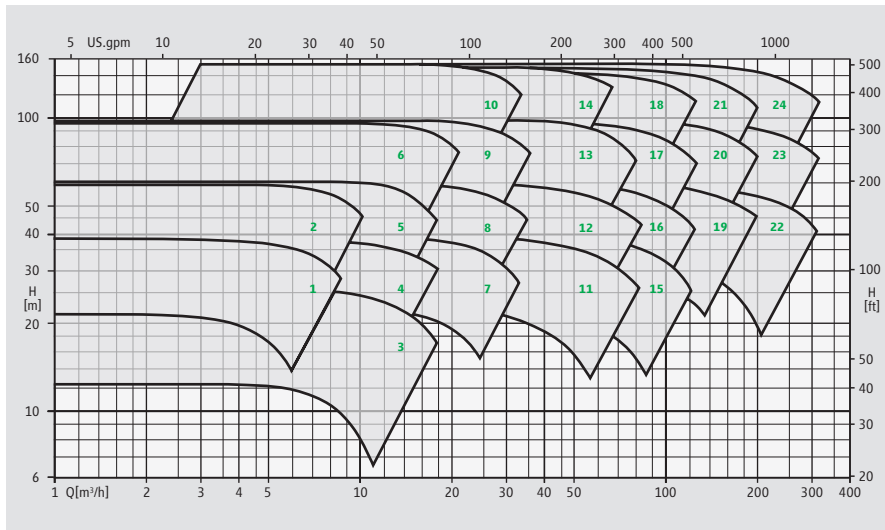

*Denomination of hydraulics to the characteristics diagram*

- |                  |                   |
|------------------|-------------------|
| <b>1</b> 25-160  | <b>13</b> 50-250  |
| <b>2</b> 25-200  | <b>14</b> 50-315  |
| <b>3</b> 32-125  | <b>15</b> 65-160  |
| <b>4</b> 32-160  | <b>16</b> 65-200  |
| <b>5</b> 32-200  | <b>17</b> 65-250  |
| <b>6</b> 32-250  | <b>18</b> 65-315  |
| <b>7</b> 40-160  | <b>19</b> 80-200  |
| <b>8</b> 40-200  | <b>20</b> 80-250  |
| <b>9</b> 40-250  | <b>21</b> 80-315  |
| <b>10</b> 40-315 | <b>22</b> 100-200 |
| <b>11</b> 50-160 | <b>23</b> 100-250 |
| <b>12</b> 50-200 | <b>24</b> 100-315 |

Characteristics diagram 1450 rpm 50 Hz

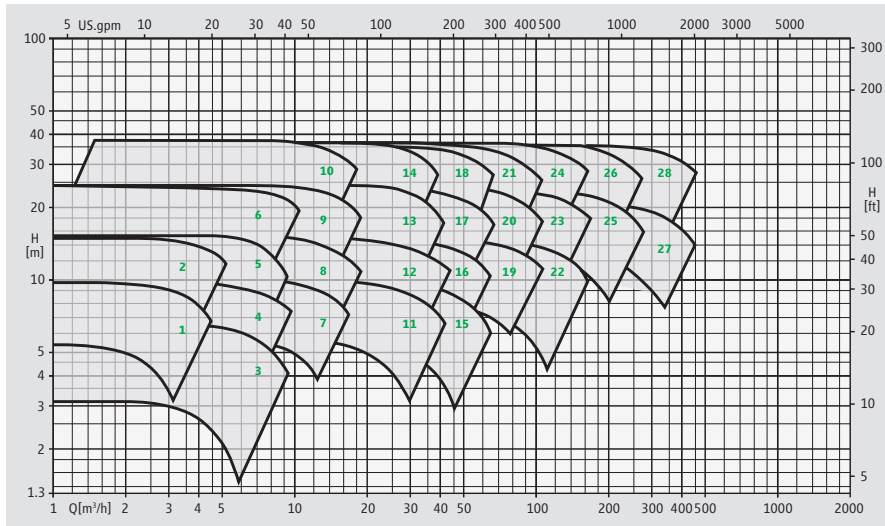

*Denomination of hydraulics to the characteristics diagram*

- |                  |                   |
|------------------|-------------------|
| <b>1</b> 25-160  | <b>15</b> 65-160  |
| <b>2</b> 25-200  | <b>16</b> 65-200  |
| <b>3</b> 32-125  | <b>17</b> 65-250  |
| <b>4</b> 32-160  | <b>18</b> 65-315  |
| <b>5</b> 32-200  | <b>19</b> 80-200  |
| <b>6</b> 32-250  | <b>20</b> 80-250  |
| <b>7</b> 40-160  | <b>21</b> 80-315  |
| <b>8</b> 40-200  | <b>22</b> 100-200 |
| <b>9</b> 40-250  | <b>23</b> 100-250 |
| <b>10</b> 40-315 | <b>24</b> 100-315 |
| <b>11</b> 50-160 | <b>25</b> 125-250 |
| <b>12</b> 50-200 | <b>26</b> 125-315 |
| <b>13</b> 50-250 | <b>27</b> 150-250 |
| <b>14</b> 50-315 | <b>28</b> 150-315 |

**Characteristics diagram 3500 rpm 60 Hz**

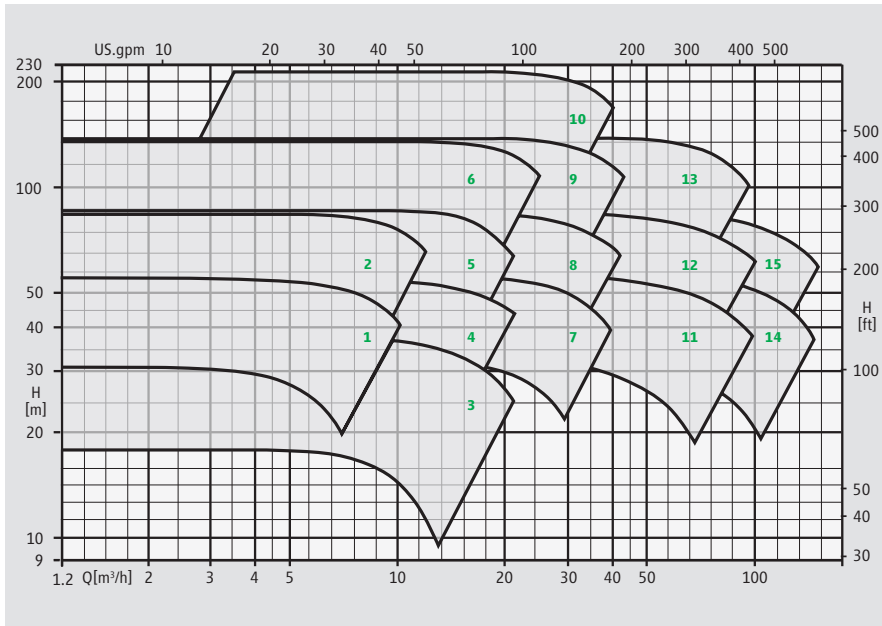

**Denomination of hydraulics to the characteristics diagram**

- |                 |                  |
|-----------------|------------------|
| <b>1</b> 25-160 | <b>9</b> 40-250  |
| <b>2</b> 25-200 | <b>10</b> 40-315 |
| <b>3</b> 32-125 | <b>11</b> 50-160 |
| <b>4</b> 32-160 | <b>12</b> 50-200 |
| <b>5</b> 32-200 | <b>13</b> 50-250 |
| <b>6</b> 32-250 | <b>14</b> 65-160 |
| <b>7</b> 40-160 | <b>15</b> 65-200 |
| <b>8</b> 40-200 |                  |

**Characteristics diagram 1750 rpm 60 Hz**

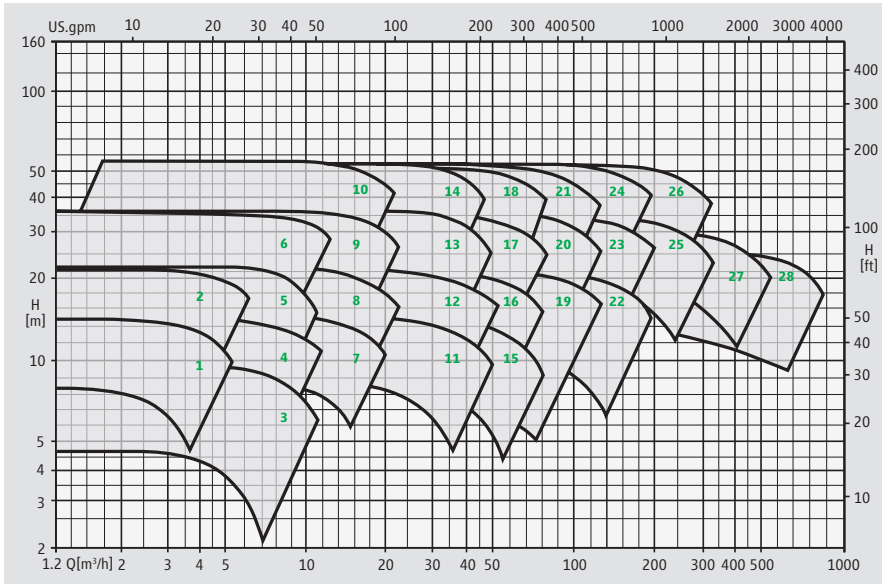

**Denomination of hydraulics to the characteristics diagram**

- |                  |                   |
|------------------|-------------------|
| <b>1</b> 25-160  | <b>15</b> 65-160  |
| <b>2</b> 25-200  | <b>16</b> 65-200  |
| <b>3</b> 32-125  | <b>17</b> 65-250  |
| <b>4</b> 32-160  | <b>18</b> 65-315  |
| <b>5</b> 32-200  | <b>19</b> 80-200  |
| <b>6</b> 32-250  | <b>20</b> 80-250  |
| <b>7</b> 40-160  | <b>21</b> 80-315  |
| <b>8</b> 40-200  | <b>22</b> 100-200 |
| <b>9</b> 40-250  | <b>23</b> 100-250 |
| <b>10</b> 40-315 | <b>24</b> 100-315 |
| <b>11</b> 50-160 | <b>25</b> 125-250 |
| <b>12</b> 50-200 | <b>26</b> 125-315 |
| <b>13</b> 50-250 | <b>27</b> 150-250 |
| <b>14</b> 50-315 | <b>28</b> 200-250 |

## Convincing service.

Important features are readiness, mobility, flexibility, availability and reliability. We are anxious to ensure a pump operation at best availability and efficiency to our customers.

### *Installation and commissioning*

- service effected on site by own service technicians

### *Spare part servicing*

- prompt and longstanding availability
- customized assistance in spare part stockkeeping

### *Repair and overhauling*

- professional repairs including test run executed by the parent factory
- or executed by one of our service stations worldwide

### *Maintenance and service agreement*

- concepts individually worked out to increase the availability of your production facilities

### *Training and workshops*

- extra qualification of your staff to ensure the course of your manufacture

### **Our products comply with:**

- Explosion protection acc. to ATEX / UL / CQST / CSA
- VOC directive 1999/13/EC
- TA-Luft
- IPPC directive
- CE
- RCCM, level 2
- Rosgortechnazdor

### **HERMETIC-Pumpen GmbH**

#### **is certified acc. to:**

- ISO 9001:2000
- GOST "R"
- ATEX 94/9/EG
- AD HP 0 / TRD 201
- DIN EN 729-2
- KTA 1401, QSP 4a