

TECHNICAL REPORT

Vertical submersible pumps in the chemical and petrochemical industry

Dr. G. Feldle



Vertical submersible pumps in the chemical
and petrochemical industry

Dr. G. Feldle

INTRODUCTION

Thanks to the EU guideline 96/61/EC (so-called IPPC guideline) as well as the Federal Immission Protection Law and the TA-Luft, emissions from pumps have been severely restricted. Today, as a consequence of these restricted regulations in environmental protection for toxic, explosive and liquefied gases, there has been an increasing tendency not to provide vessels and vessel drains with a lateral outlet or bottom outlet, i.e. with a drain nozzle installed in the range of the bottom.

For such application cases vertical submersible pumps are generally the preferred choice. Besides conventional submersible pumps with stuff box packing or single and double mechanical seals, also hermetically sealed pumps have been increasingly used that do not have any shaft sealing and thus, they are completely leakage-free. In general, these are magnetic drive pumps (MDP) or canned motor pumps (CMP).

These three pump types are characterised as follows. Pumps with shaft seal and the two of the mentioned seal-less centrifugal pump types. The advantages and disadvantages of these pumps are being discussed and evaluated.



Vertical submersible pumps in the chemical
and petrochemical industry

Dr. G. Feldle

FUNCTION AND CONSTRUCTION

The sealing of the shaft passage at the pump casing is a critical point with conventional centrifugal pumps. There is always some liquid leaking from the shaft seal, however, this is not always visible. This problem can be resolved by a double mechanical seal. Higher safety is provided by hermetically sealed pumps, such as canned motor pumps and pumps with magnetic coupling, because they do not have the "shaft seal" weak point, and nothing can leak out. These pumps are known as hermetically sealed pumps.

The canned motor and magnetic drive pumps are special as a result of the kind of drive utilised, otherwise they are "standard" pumps. Pumps with magnetic drive have, in contrast to canned motor pumps, a conventionally external motor. The torque is transmitted by the containment shell onto the shaft in the pump.

The magnetic coupling consists of inner and outer rotors that are both equipped with permanent magnets. The inner rotor is located on the impeller shaft and is driven by the outer rotor that is located on the motor shaft. The magnetic attraction between the poles drives the coupling.

With both rotors the orientation changes from north pole to south pole from magnet to magnet. Thus, the magnetic coupling is characterised alternately by north pole – south pole and south pole – north pole combinations.

The sealing element between the inner and outer rotor is taken by the containment shell. The impeller, slide bearing and the internal rotor are located in the medium.

The drive is normally separated from the pump (e.g. electro-motor). The torque is transmitted from the outer motor through a mechanical coupling to the pump impeller. If you install the motor into the pump you may refrain from the shaft passage at the casing.



Vertical submersible pumps in the chemical and petrochemical industry

Dr. G. Feldle



Figure 1: Conventional submersible pump

As everybody knows, an electric motor consists of two main parts; the rotor and the stator, which are separated from each other in the canned motor pump by the can of the motor

The conveyed liquid is in the can of the motor, i.e. it is wet. There is the rotor and the two slide bearings in which the shaft is running. The rotor is connected with the impeller through the shaft. Outside of the can of the motor – and so in the dry – are the winding motor and the electric terminals. The slide bearings are being lubricated by the conveyed liquid.

LATEST TECHNOLOGY

Today, in the chemical and petrochemical industry, conventional pumps are mainly being used with mechanical seal.

Figure 1 shows a conventional submersible pump in vertical design. The hydraulic part is arranged above close to the vessel bottom. The pressure line is placed in parallel to the pump drive shaft via manhole door to the outside. The impeller is arranged at the shaft which is fixed by medium-lubricated guide bearings. Depending on the immersion depth several bearings will be required. The following reference value will apply: according to the pump size, one guide bearing per 1,2 m to 1,6 m is required. The bearings are installed in a support pipe that is fixed to the manhole door. The sealing to the atmosphere is effected by using a mechanical seal. The conventional drive motor is installed outside the vessel and can be used for every protection type according to the explosion requirements.

The basic and outer construction of a conventional pump with mechanical seal can be compared with the design of a submersible pump with magnetic drive. [Figure 2]

Vertical submersible pumps in the chemical and petrochemical industry

Dr. G. Feldle

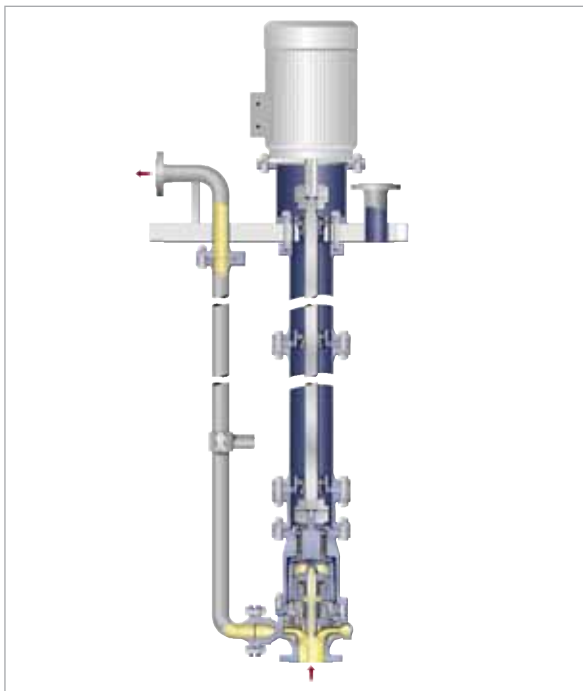

Figure 2: Submersible pump with magnetically coupled drive

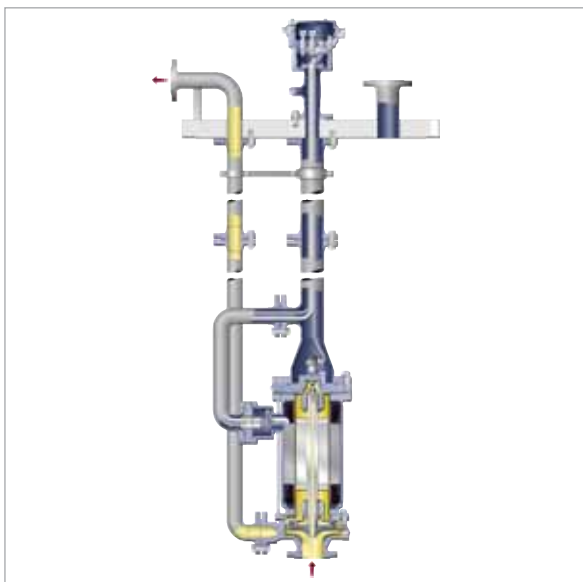

Figure 3: Submersible pump with canned motor

The difference of sealing to the atmosphere is the containment shell of the magnetic coupling that is directly installed to the pump component. The containment shell ensures an absolute leakage-free pump operation and can also be installed on the outside of the vessel.

Because of that, the drive shaft of this construction type is not medium-lubricated but operates in a dry place. The bearings used are prelubricated roller bearings which are placed in a support tube under dry conditions.

The cable passage at the manhole door is sealed by a mechanical seal. According to the depth of assembly several bearings need to be installed here as well. Statistically the service-life of roller bearings is, as already known, restricted. Depending on the explosion protection also conventional electric motors can be used here as a drive.

When installing canned motor pumps the drive shaft having a length according the immersion depth is no longer needed.

The rotating parts of the pump shaft are placed in the canned motor pump and are therefore extremely short. [Figure 3] The pump is fixed to a support pipe which is arranged at the manhole door. The single task of the support pipe is to carry the pump and to lead the cables to the outside. Medium-lubricated guide bearings or prelubricated roller bearings are not necessary since the usually used long drive shaft is not required for operational reasons, i.e. the drive shaft of vertical submersible pumps with canned motor is always of the same shortness not depending on the immersion depth, however, the length of the drive shaft of conventional submersible pumps with mechanical seal and with magnetic drive pumps has been designed accordingly. Thus, the length of the drive shaft with the required bearings depends on the function of the immersion depth.

Therefore, of course, when there is an increase in the immersion depth the tendency that these pump types with the respective number of guide bearings will become more sensitive is then increased as well.

Vertical submersible pumps in the chemical
and petrochemical industry

Dr. G. Feldle

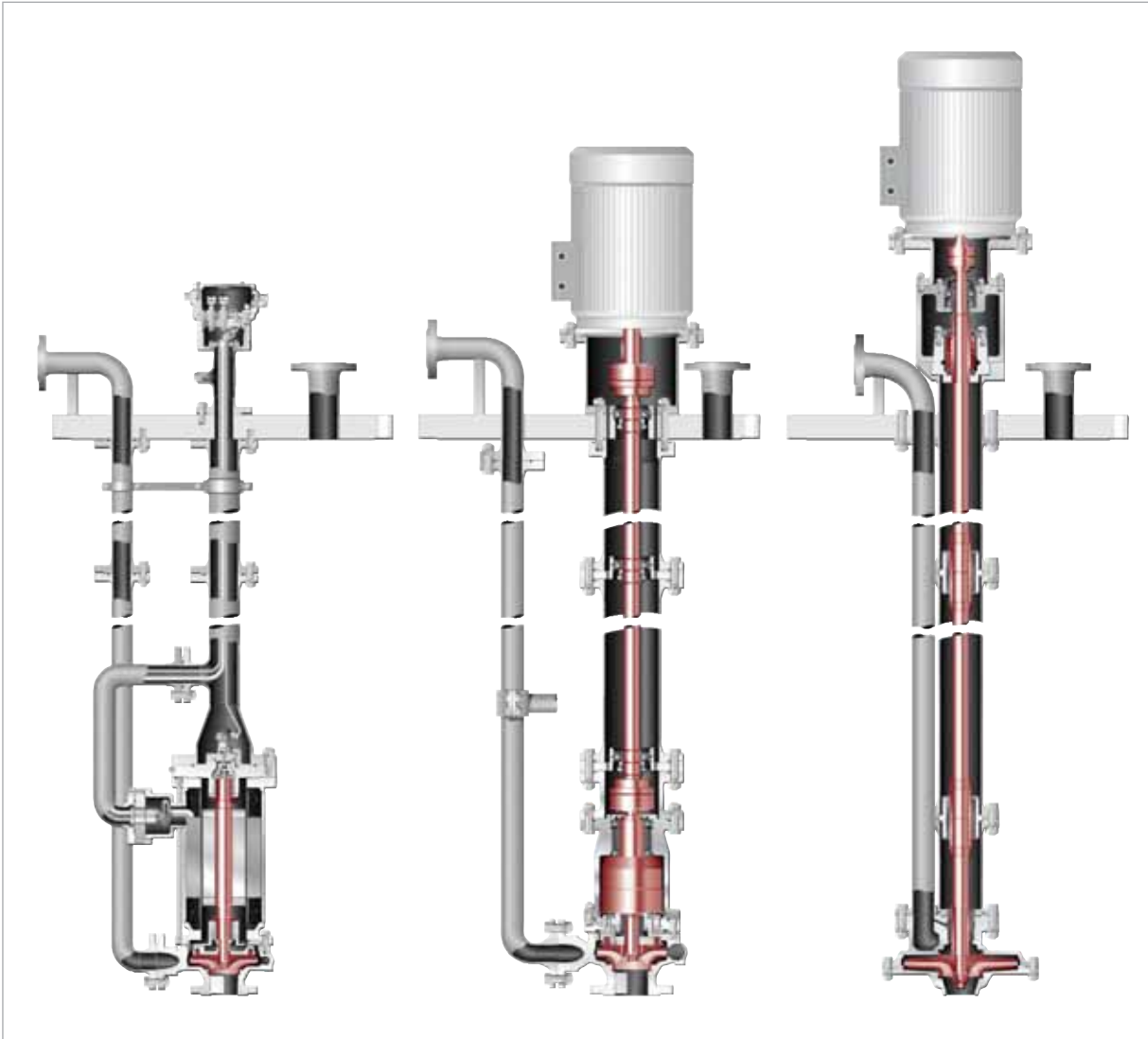

Figure 4: Comparison of the three submersible constructions

The second significant disadvantage is deemed to be the required seal to the drive shaft at the manhole door to the atmosphere.

Figure 4 clearly shows the proportion of the rotating shafting depending on the construction and same immersion depth.

Vertical submersible pumps in the chemical and petrochemical industry

Dr. G. Feldle

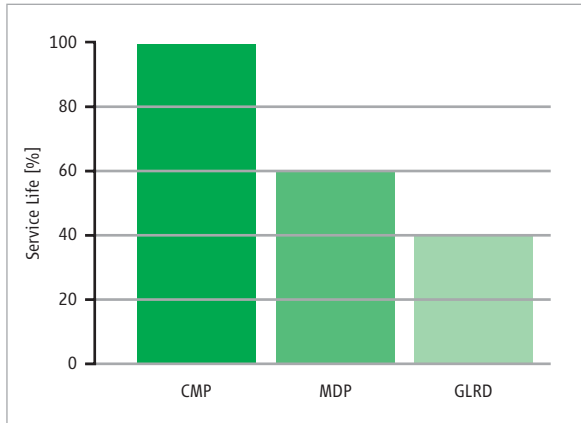

Figure 5: Service life of various centrifugal pump types

CMP canned motor pump
 MDP magnetic drive pump
 GLRD mechanical seal pump

INFLUENCES ON THE TOTAL COSTS

Besides the known characteristics of prelubricated roller bearings and medium-lubricated slide bearings the expenditure of work and time required for removing this pump is of significant importance.

The drive shafts need to be selected in smaller segments with flange connections or couplings in order keep the construction costs at a low level. As a consequence, of course, this results in an additional sensitiveness of the pump in regard to the bearings. If the shaft has been installed as one part, the mounting costs will rise since the pump casing needs to be designed according to a suitable height.

When installing and removing the pump from the tank, there will be additional costs arising out of the scaffold, removing of insulation, disconnecting and connecting of measuring and controlling instruments, as well as other mechanical work.

It is therefore important to know that canned motor pumps achieve the longest service life [Figure 5] even if the repair costs are deemed to be higher than with conventional pumps and magnetic drive pumps.

Vertical submersible pumps in the chemical and petrochemical industry

Dr. G. Feldle

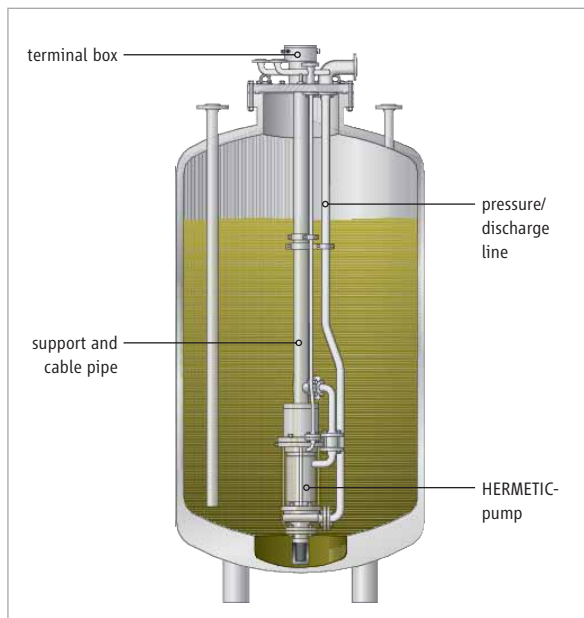

Figure 6: Installation vessel pump

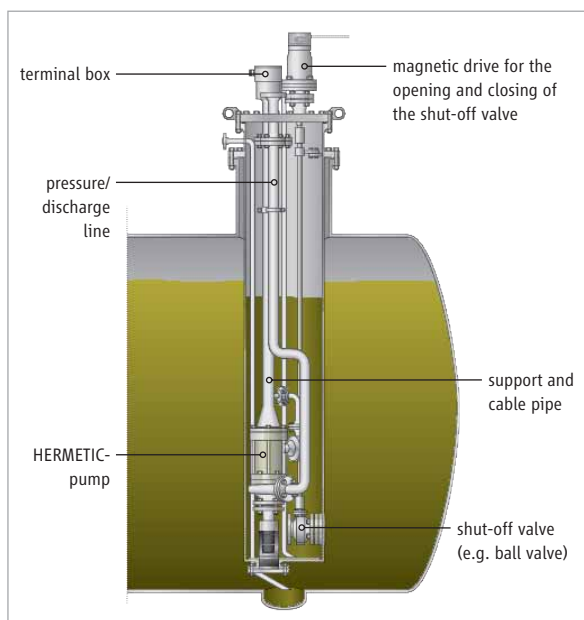

Figure 7: Installation pump with the opportunity to separate the pump from the liquid in the vessel.

INSTALLATIONS

The HERMETIC canned motor submersible pump provides the optimum solution for difficult installations. Essentially there are two different installations in the tank and in the vessel:

- direct placing in the tank [Figure 6]
- installation of the pump with the opportunity to separate the pump from the liquid in the vessel [Figure 7]

The direct placing of the submersible pump in the tank is recommended for small container volumes, e.g. for NPSHA improvement in vessel loading/unloading stations.

To inspect the pump with a filled tank it is necessary that the pump is removed and reinstalled. The installation when the pump is separate from the liquid proves to be the best optimum solution.

In this system, there is a shut-off valve close to the tank bottom, which can be operated with a gear or with a pressure medium run system.

The delivery medium can be pushed back into the tank by inertisation. After closing of the valve and releasing the pressure the submersible pump can be removed or installed without emptying the vessel.

SUMMARY

The initially mentioned EC directive, which is reflected in the Federal Immission Protection Law and the TA-Luft, seal-less pumps, particularly the canned motor pumps in this case, are increasingly being used as "Best Available Technology" (BAT) to prevent and reduce volatile emissions.